

다중경로 페이딩 채널에서 멀티캐리어 코드분할다중접속 시스템 성능 분석

이 관 형*, 이 명 호**

On the Performance of Multicarrier CDMA Systems in Multipath Fading Channel

Kwan-Houng Lee *, Myung-Ho Lee **

요 약

본 논문에서는 신호대 잡음비를 향상시키는 새로운 다이버시티 알고리즘을 제안한다. 무선채널에서는 다중경로로 인하여 페이딩이 발생하여 시스템 성능이 감소한다. 페이딩을 감소시키는 방법중의 하나가 다이버시티기법이고, 새로운 다이버시티 기법을 제안하여 시스템 성능을 향상시키는 것이 본 논문의 목적이다. 수신기는 레이크수신기를 적용하였다. 변조방식은 QPSK, OQPSK를 적용하였고, 부호화율이 1/3이고, 구속장이 9인 길쌈부호와 구속장이 4인 터보코드를 적용하였다. 이와 같은 조건에서 본 논문은 다중캐리어 CDMA시스템에서 평균에러 확률을 비교 분석하였다.

Abstract

This study proposes a new diversity algorithm to improve the signal-to-noise ratio. In the wireless channel, if fading occurs due to the multipaths, the performance of the system is apparently reduced. One of the methods to reduce fadings like this is the diversity method, and this study aims to improve the performance of the system by proposing a new diversity algorithm. This study applied rake receiver. It applied QPSK and OQPSK modulation methods and applied the convolutional codes, where the code rate is 1/3 and the constraint length is 9, and the turbo code where the constraint length is 4. Under these conditions, this study compared and analyzed the average error probability of Multicarrier CDMA system.

▶ Keyword : CDMA, Diversity, QPSK, OQPSK

• 제1저자 : 이관형
• 접수일 : 2006.04.26, 심사일 : 2006.05.11, 심사완료일 : 2006.06.10
* 청주대학교 전자정보공학부 전임강사 ** 청주대학교 전자정보공학부 교수

I. 서론

Generally, the history of mobile communication refers to the 1st generation of AMPS, the 2nd generation of cellular, the 2.5th generation of PCS and the 3rd generation of IMT2000 (WCDMA, CDMA2000), and is marked with such significant developments. At that time too, the study on the 4th system of OFDM (Orthogonal Frequency Division Multiplexing) was in progress[1]. From the 2nd generation, digital communication was the preferred communication method for the following reasons. First, the digital transmission, through efficient utilization of the frequency, can accommodate 3 to 5 times more subscribers compared to the previous analog method. Second, the use of digital communication requires less battery generation power and less number of chips for mobile station intelligence, so that it largely reduces the cost of the mobile station. Third, as it transmits the digital message, it enables the use of the code system and improves the level of privacy of the subscribers. Fourth, digital communication provides a wide range of services, including the transmission of data.

CDMA (Code Division Multiple Access) method, a kind of multiple access system, uses a different spectrum-spread codes to distinguish the users. The spectrum-spread methods include the DS (Direct Sequence) method and the FH (Frequency Hopping) method. The DS method uses orthogonal spread codes like WALSH function, so that N numbers of channels become multiplexing in the same frequency range during same hours. Since CDMA method is appropriate to the mobile wireless channels having heavy multipaths, it started to be used in new areas like IMT 2000, WLAN, and DMB.

This study aims to find out the bit error probability of CDMA system in the mobile wireless channel as proposed in the new diversity

algorithm. For this, this study assumes that it resolves the wireless channels into multipaths and the receiving signal has Rayleigh distribution. This paper is organized as follows. In Chapter II, it explains Multipath Fading channels. In Chapter III, explains MC-CDMA system, it proposes the diversity algorithm to assess the performance of the system. In Chapter IV, it compares and analyzes the system performance of the CDMA method using rake receiver. Finally, it describes the conclusion in Chapter V.

II. Multipath Fading Channel

2.1. CDMA

The direct spread method causes the transmitting signals to be recognized as noise to other users but the receiver, making the data difficult to detect or extract. This method modulates the signals by spreading the data signal in the bandwidth using PN codes and modulates them again by spreading signals having wider bandwidth. There are two advantages of using the CDMA methods[2]. First, it uses the simple spread method second, the error is random. In other words, as its interference is spread in the receiver CDMA system, the interference within the bandwidth seems to increase the level of the noise on the receiver[3]. However, the voice signals without error correction have larger tolerance level for burst error, so that the information data is easily corrected by Trellis error correction and Viterbi decoder.

2.2. Rician Fading

The MGF for a non-centralized chi-squared RV(Rice distribution) is given by[4]

$$p(r) = \frac{1+G}{1+G+rs} \exp\left(\frac{-Gr\bar{s}}{1+G+rs}\right) \dots\dots\dots (1)$$

where G denotes the Rice parameter, which is the

ratio of the power in the line-of-sight and specular components to that in the diffuse component.

2.3. Rayleigh Fading

In the mobile wireless communication system, multipaths are formed due to the reflection, refraction, and scattering of signals affected by buildings, man-made constructions, or natural environment. Likewise, it is difficult for the signals received from a mobile device to have line-of-sight waves from the sender. These waves are the sum of signals, which were scattered by disarranged obstacles, causing diminution and phases differences on each signal received. When there is no line-of-sight wave and only reflective waves exist, it is referred to as Rayleigh fading. Rayleigh fading has Rayleigh distribution and the equation of Rayleigh distribution is as follows[4].

$$p(r) = \frac{r}{\sigma^2} \exp\left(-\frac{r^2}{2\sigma^2}\right) \dots\dots\dots (2)$$

When we think of the multipath fading of two different frequencies separated within a system bandwidth, in case where the interval of those two frequencies are small enough, those two waves pass almost in the same electromagnetic paths so that they have almost same amplitude and changes in phase. However, the bigger the interval between those two frequencies is, the smaller the level of the correlation between the patterns of the changes of those two frequencies becomes. This is because the changes of phases between two frequencies are different upon each path in the multipath environment. This phenomenon, which shows different fading according to the frequency, is called frequency selective fading. The bandwidth, which has small enough level of correlation of fading between two frequencies, is called Coherence Bandwidth. This coherence bandwidth is related to the delay spread. In the areas with large delay spread, the coherence bandwidth becomes smaller because the phases of signal received have large

differences even though the interval between two frequencies is small. While in the area which has small delay spread, the bandwidth becomes larger.

2.4. Nakagami-m and Nakagami-q Fading

The MGF for the Nakagami-m fading channel can be obtained from[4]

$$p(r) = \left(\frac{m}{m+r/s}\right)^m, \quad m \geq 0.5 \dots\dots\dots (3)$$

where *m* denotes the fading figure. It is evident that(3) reduces to the Rayleigh fading case when *m*=1.

It can be easily shown that the MGF of the received power for the Nakagami-q fading is,

$$p(r) = \frac{1}{\sqrt{[rs(1+b)+1][rs(1-b)+1]}} \dots\dots\dots (4)$$

, $-1 \leq b \leq 1$

where $b = [1-q^2]/[1+q^2]$ and $q (0 \leq q \leq \infty)$ is the fading parameter. In particular, the Nakagami-q distribution reverts to the Rayleigh and the one-sided normal distribution when $b = 0$ and $b = 1$, respectively.

2.5. Lognormal-Rice and Suzuki Fading

Expressing the received fading envelop as the product of independent Rice and lognormal distributions, and then applying Hermitian integration, we can show

$$p(r) = \frac{1}{\sqrt{\pi}} \sum_{i=1}^N \frac{w_i(1+F)}{1+F+r\mu \exp(\sqrt{2}\sigma x_i)} \dots\dots\dots (5)$$

$$\times \exp\left(\frac{-Fr\mu \exp(\sqrt{2}\sigma x_i)}{1+F+r\mu \exp(\sqrt{2}\sigma x_i)}\right) + R_H$$

where σ is the logarithmic standard deviation of shadowing, and μ is the local mean power. The abscissas x_i (*i*th root of an *N*th order Hermite polynomial) and weights w_i are tabulated for $N \leq 20$

and R_H is a remainder term. Since Suzuki distribution is a special case of the lognormal Rician distribution, its MGF is readily obtained by setting $F = 0$

2.6. Lognormal-Nakagami-m Fading

Similar to our derivation of [4], the MGF of the received power in a Nakagami-m fading channel with lognormal shadowing can be expressed as,

$$p(r) = \frac{1}{\sqrt{\pi}} \sum_{i=1}^N \frac{w_i}{[1+r\mu\exp(\sqrt{2}\sigma x_i)/m]^m} + R_H \dots\dots\dots (6)$$

2.7. Channel Model

In order to provide a comprehensive performance analysis, we employ the correlation function of the fade envelopes to describe the multicarrier channels, and we define a time-domain model for the MC RAKE system. The channel is assumed to be a slowly varying, frequency selective, Rayleigh channel with a coherence bandwidth of $(\Delta f)_c$, which can be predicted from the fade envelope correlation function. The low pass impulse response of the bandpass channel for the k th user may be written as

$$h_k(t) = \sum_{l=0}^{L-1} \beta_{lk} e^{j\theta_l} \delta[\tau - \tau_{lk}] \dots\dots\dots (7)$$

Each path is characterized by three variables : its strength β_l , phase shift θ_l and propagation delay τ_l . Although the number of paths, L , may be a random number, it is bounded by[5]

$$L = \left\lceil \frac{T_m}{T_c} \right\rceil + 1 \dots\dots\dots (8)$$

where, T_m is the maximum delay spread of the channel, and T_c equals the resolution provided by the transmitted wideband signal. T_m is assumed to be much less than the bit interval T , in order to reduce intersymbol interference(ISI).

III. MC-CDMA system

The transmitter and receiver of the system are shown in Fig.2 and 3, respectively. At the transmitting side, the bit stream with bit duration T_b is serial-to-parallel converted into M parallel streams. The new bit duration on each streams is $T = MT_b$. Each stream feeds S parallel streams such that the same data stream exists on the S branches. The S branches carrying the same data stream are denoted as identical-bit branches, and after modulation, the frequencies carrying the same data stream are denoted as identical-bit carriers.

On the identical bit branches the data streams are interleaved such that on two contiguous branches, the replicas of the same bit are separated by an interval. This interleaving is required to achieve time diversity. All data streams are spread by the same PN code of length N and chip duration T_c such that $T = NT_c$. One of MS orthogonal carriers is used for QPSK modulation of each stream.

The transmission BW is assumed to be the pass-band null-to-null $BW(2/T_{cl})$, where, T_{cl} is the PN code chip duration for single carrier case($M = S = 1$). The total BW in case of MS carriers is given by:

$$BW = \frac{MS+1}{T_c} \dots\dots\dots (9)$$

To keep the BW fixed for any selections of M and S , the PN code chip T_c duration must be as follow.

$$T_c = \frac{MS+1}{2} T_{cl} \dots\dots\dots (10)$$

Consequently with $T_c = MT_b/N$, $T_{cl} = T_b/N_1$ the period N of the PN sequence must be as follows.

$$N = \frac{2M}{MS+1} N_1 \dots\dots\dots (11)$$

Where N_1 is the processing gain in single carrier case ($M = S = 1$).

3.1. Transmitted Signal

In CDMA system of K users transmitting simultaneously, the transmitted signal for the k th user is a phase coded carrier, which may be written as[5]:

$$S_k(t) = \sum_{m=1}^{MS} \sqrt{2P} a_k(t) b_{k,m}(t) \cos(\omega_m t + \phi_{k,m}) \dots\dots\dots (12)$$

where $a_k(t)$ and $b_k(t)$ are the code and data sequences of the k th user, $p = 1 + [(m-1) \text{ mod } M]$ respectively.

$$a_k(t) = \sum_{i=-\infty}^{\infty} a_{i,k} P_{T_c} (t - iT_c) \dots\dots\dots (13)$$

where, $a_{i,k}$ is data symbol. P is the average transmitted power, which is common to all the users, assuming perfect power control scheme, ω_m is the m th carrier frequency, and $\phi_{k,m}$ is the phase angle of the k th modulator. The phase angle, $\phi_{k,m}$ is assumed to be uniformly distributed in $[0, 2\pi]$. T_c is the chip duration, T is the data bit duration. we take $N = T/T_c$ to be the processing gains of the spread-spectrum system.

The carrier frequencies ω_m are related by.

$$\omega_m = \omega_1 + (m-1) \frac{2\pi}{T_c} \dots\dots\dots (14)$$

where $m = 1, 2, \dots, MS$, m is the absolute carrier number in the system. Note that if the relative carrier number within group P is v where $v = 1, 2, \dots, S$, then the absolute carrier number in

the system can be written as: $q = p + M(v-1)$.

The receiver of user k employs MS Matched Filter detectors, each tuned and synchronized to one of the carriers. The matched filter outputs of the identical-bit carriers are de-interleaved and the decision statistics of the same bit are added prior to the threshold device in an MRC. The multipath Nakagami fading channel given in section II is assumed. when the maximum delay spread of the channel is T_m the number of resolvable paths L is given by equation(8). Assume that $T_m = n_1 T_{c1}$ for some integer n_1 and by applying(10) L is given by:

$$L = \left\lceil \frac{2(L_1 - 1)}{MS + 1} \right\rceil + 1 \dots\dots\dots (15)$$

where, L_1 is the number of resolvable paths for the single carrier case. Obviously from(14) the number of resolvable paths decreases as the number of carriers increases if :

$$MS > (2L_1 - 2) \dots\dots\dots (16)$$

Then $L = 1$ and the channel is a single path fading channel for each carrier.

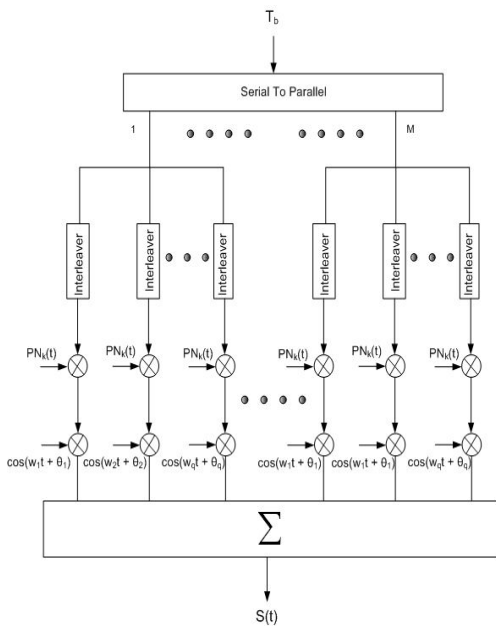

Fig.1 Multicarrier CDMA transmitter for M parallel branches with S carriers per branch
 그림1. S 캐리어의 경로와 M 병렬 경로의 MC-CDMA송신기

3.2. Received Signal

Figure3. is the CDMA communication system model showing that K number of users exist[6][7][8]. The data signal of the users, $b_k(t)$, is a rectangle wave wand's sequence having +1 and -1 of values for T seconds of the section and displayed as follows.

$$b_k(t) = \sum_{l=0}^{\infty} b_{k,l} P_T(t-lT) \dots\dots\dots (17)$$

Here, the $b_{k,l}$ is the l^{th} data of k^{th} user. When $t = T$, the output of correlation receiver is displayed as follows.

$$Z_i = \sqrt{\frac{P}{2}} \left\{ b_{i,0} T + \sum_{\substack{k=1 \\ k \neq i}}^K [b_{k-1} R_{k,i}(\tau_k) + b_{k,0} \hat{R}_{k,i}(\tau_k)] \cos \phi_k \right\} + \int_0^T n(t) a_i(t) \cos \omega_q(t) dt \dots\dots\dots (18)$$

where, $R_{k,i}$ and $\hat{R}_{k,i}$ is partial cross correlation as follows.[10][11]

$$R_{k,i}(\tau) = \int_0^\tau a_k(t-\tau) a_i(t) dt \dots\dots\dots (19)$$

$$\hat{R}_{k,i}(\tau) = \int_\tau^T a_k(t-\tau) a_i(t) dt \dots\dots\dots (20)$$

The Z_i distribution can be displayed as follows.

$$Var \{ Z_i \} = \frac{PT^2}{12N^3} \left[\sum_{\substack{k=1 \\ k \neq i}}^K r_{k,i} \right] + 1/4N_o T \dots\dots\dots (21)$$

The average signal-to-noise ratio input in the receiver is as follows[9].

$$\gamma_c = \left\{ (6N^3)^{-1} \sum_{\substack{k=1 \\ k \neq i}}^K [2\mu_{k,i}(0) + \mu_{k,i}(1)] + \frac{N_o}{2E_b} \right\}^{-1} \dots\dots\dots (22)$$

$$\mu_{k,i} = \sum_{l=1-N}^{N-1} C_{k,i}(l) C_{k,i}(1+n) \dots\dots\dots (23)$$

$\mu_{k,i}$ is cross-correlation parameter. $C_{k,i}$ is cross-correlation function of spread code about user of i^{th} and k^{th} .

In Equation (5), it was normalized when the value of K value was large[10],

$$(6N^3)^{-1} \sum_{\substack{k=1 \\ k \neq K}}^K r_{k,i} \approx \frac{(k-1)}{3N} \dots\dots\dots (2)$$

and the average signal-to-noise ratio input in the receiver is displayed as follows.

$$\gamma_c = \left\{ \frac{K-1}{3N} + \frac{N_o}{2E_b} \right\}^{-1} \dots\dots\dots (25)$$

Here, K is the number of users, and N is the code sequence.

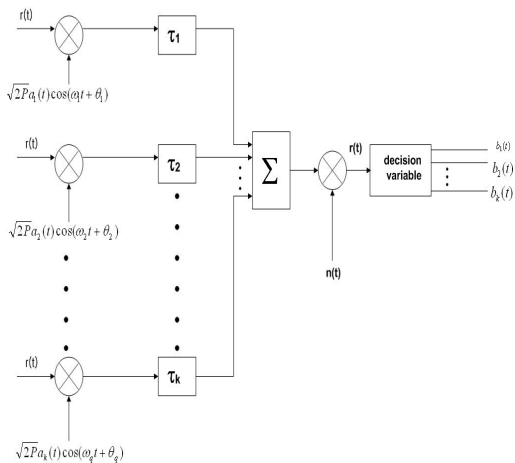

Fig 2. Multicarrier CDMA Receiver model
 그림 2. MC-CDMA 수신기 모델

IV. System Performance Analysis

The error probability of QPSK in the AWGN, P_e can be displayed as follows.

$$P_e(\gamma) = \frac{1}{M} \sum_{p=1}^M \int_0^\infty \frac{1}{2} \text{erfc}(\gamma) \dots (26)$$

The signal-to-noise ratio in cases where the diversity method was introduced in the multipath fading channel can be described as follows.

$$\gamma = M \cdot \gamma_c \dots (27)$$

Here, γ is the bit per signal-to-noise ratio and γ_c is the channel per signal-to-noise ratio. It used a rake receiver and applied maximum synthesis method. In this case, the number of antennas was A_n . If there is L number of incidence signal paths, the total number of diversity of this system can be displayed as follows.

$$M = L_s \cdot L \dots (28)$$

where, L_s is antenna element number.

The bit per signal-to-noise ratio can be described as follows.

$$\gamma = \left[\left[\frac{2(L_s - 1)}{MS + 1} \right] + 1 \right] \left[\frac{(K - 1)}{3N} + \frac{N_o}{2E_b} \right]^{-1} \dots (29)$$

The average error probability P when QPSK signal receives Rayleigh fading in the AWGN can be presented as follows[11].

$$P = \int_0^\infty p(\gamma) P_e(\gamma) d\gamma \dots (30)$$

V. Simulation

In this chapter, this study aims to compare and analyze the average error probability of MC-DS CDMA system. The study set the number of antenna as 9, and assumed that there are 700 users in a single set. For the channel distribution, it applied the Nagakami fading distribution and set the fading index as 1. The code rate was 1/2 and 1/3, and QPSK and OQPSK modulation methods were used. Table 1 display the results of the MC-DS CDMA system performance analysis applying QPSK and OQPSK modulation methods.

The Normal 1 graph in Figure 4. applied a code rate of 1/2, diversity method, convolutional code, and turbo code. The Normal 2 graph applied a code rate of 1/3, diversity method, convolutional code, and turbo code. The Proposed graph applied the diversity algorithm proposed by this paper to the MC-DS CDMA system.

Table 1. Comparison of E_b/N_o of QPSK and OQPSK system
표1. QPSK 와 OQPSK 시스템의 E_b/N_o 비교

Modulation	Method	Code rate	E_b / N_o
QPSK	normal 1	1/2	$10^{-2.4}$
	normal 2	1/3	$10^{-2.7}$
	proposed	1/3	$10^{-2.9}$
OQPSK	normal 1	1/2	10^{-3}
	normal 2	1/3	$10^{-3.3}$
	proposed	1/3	$10^{-3.5}$

The average error probabilities of Normal 1 and Normal 2 when E_b/N_o is 20 dB are $10^{-2.4}$ and $10^{-2.7}$ respectively and that of the Proposed is $10^{-2.9}$ where it was proven that the performance of the diversity algorithm proposed by this study is superior to the others.

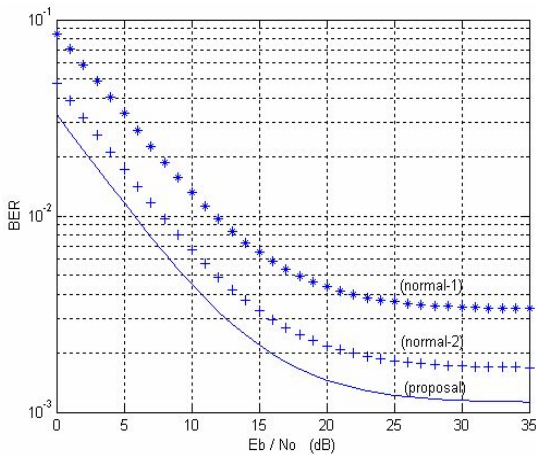

Fig 3. BER of QPSK system
그림 3. QPSK 시스템의 비트에러확률

Figure 4 shows the average error probabilities upon each modulation method. When E_b/N_o is 20 dB, the average error probabilities of Normal 1, Normal 2 and the Proposed were 10^{-3} , $10^{-3.3}$ and $10^{-3.5}$ respectively and it also showed that the diversity algorithm proposed by this study is superior to the others in the OQPSK modulation method.

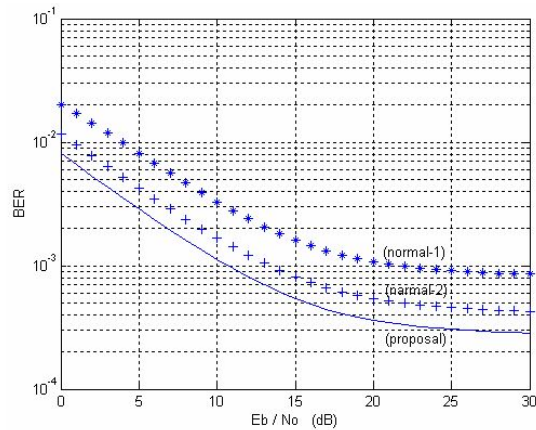

Fig 4. BER of OQPSK system
그림 4. OQPSK 시스템의 비트에러확률

VI. Conclusion

This study proposed a new diversity algorithm to reduce the average error probability. In Figure 4, where BER is 10^{-2} , it improved 7dB in the proposed algorithm compared to that in Normal 1, and 5dB was an improvement over that of Normal 2. In Figure 4, where BER is 10^{-2} , it improved 5 dB in the proposed algorithm compared to that of Normal 1, and about 3dB was an improvement over that of Normal 2. Therefore, these proved the superiority of the diversity algorithm proposed by this study. Comparing Figure 3 and Figure 4, the QPSK was $10^{-2.9}$ and OQPSK was $10^{-3.4}$ a finding again, that the diversity algorithm proposed in this study is more appropriate to the OQPSK modulation method.

참고문헌

- [1] Shinsuke Hara. Multicarrier Techniques for 4G mobile communications, Artech House 2003, pp.10-90

[2] L.Hanzp, L-L Yang ,E-L,Kuan, K.Yen. Single-and Multi-Carrier DS-CDMA, IEEE PRESS 2003, pp.1-309

[3] W.C.Y.Lee. "overview of Cellur CDMA." IEEE Trans. Vehic, vol.40, pp.291-302,May 1991

[4] Elnoubi, S.M Hasbem, A.A, "Performance of code division Multiple Access CDMA Systems In Nakagami Multipath Fading Channel",NRSC Proceeding, vol.1, Mar 2001, pp.217-224

[5] Weiping Xu, Laurence B. Milstein,"On the Performance of Multicarrier RAKE Systems", IEEE Tran. Com, vol.49, No.10, Oct 2001,pp.1812-1823

[6] Michaelb.parsley,"Performance evaluation for phase coded spres-spectrum multiple-access commicaion-part1:Analysis." IEE Tran.commun, vol COM-26 ,No.8 Aug . 1977

[7] P.Seite,J.Tardivel,"Performance of Space Diversity DS/CDMA System", IEEE Commun society ICUPC94, September 27, 1994,pp 42-45.

[8] H.xing,"Binary Code-Division Multiple- Access Systems Operating in Multipath Fading, Noise Channels", IEEE Tran. Commun, vol.Com-33, pp775-784, Aug ,1985

[9] John G.Proakis, Digital Communications, McGraw Hill 1991, pp.702-790

[10] 강진구, 이관형 "가격함수 및 비전정보를 이용한 이동매니플레이터의 작업수행", 한국컴퓨터 정보학회 논문집 제10권 제6호, PP.345-354, 2005

[11] 이관형,송우영. "WTDL을 이용한 개인통신망의 최적 접속방법에 관한 연구", 한국OA학회 논문집 제3권 제 3호, pp.121-127, 1998

저자 소개



이관형

1994년 2월 : 청주대학교
전자공학과(학사)

1996년 8월 : 청주대학교
전자공학과(공학석사)

2004년 8월 : 청주대학교
전자공학과(공학박사)

2005년 3월 ~ 현재 :
청주대학교 전자정보 공학부
전임강사
<관심분야>무선이동통신



이 명 호

1979년 2월 : 광운대학교
전자통신과(공학사)

1981년 2월 : 연세대학교
전자공학과(공학석사)

1991년 2월 : 연세대학교
전자공학과(공학박사)

1984년 3월~ 현재 :
청주대학교 전자정보
공학부 교수
<관심분야>데이터통신