

HPR: 중첩된 이동 망에 대한 계층적 프리픽스 라우팅

노경택*

HPR: Hierarchical Prefix Routing for Nested Mobile Networks

Kyung-Taeg Rho *

요약

이동망지원프로토콜은 이동 망으로 하여금 인터넷상에 위치 변경을 가능하도록 하는 프로토콜이지만, 최적이 아닌 라우팅과 전송패킷의 다중 헤더를 요하는 문제점을 지니고 있다. 프리픽스 할당 (PD) 프로토콜과 계층적 이동 인터넷 프로토콜 (HMIPv6)의 개념을 결합하여 생성한 제안 스킴은 효율적인 경로 최적화를 지원하고, 핸드오프로 인한 패킷 손실을 감소시키고, 그리고 요구되는 위치갱신의 비용을 감소시키는 장점이 있다. 또한 제안 스킴은 이동 망 노드로 하여금 계층적 이동 망 프리픽스 (HMNP)를 이용하여 이동주소를 갖도록 하고, 미시적 이동성을 지원한다. 본 논문에서 이동성 관리 라우터 (MMR)로 하여금 중첩된 이동 망 내에 존재하는 모든 이동 망 노드들에 대한 바인딩 정보를 지니도록 하고, 또한 이동 망의 위치변경으로 인하여 발생하는 핸드오프 신호의 양을 줄이기 위한 바인딩 절차를 지원한다. 본 논문에 대한 성능평가는 NS-2를 이용하였다.

Abstract

Network Mobility Basic Support protocol enables mobile network to change their point of attachment to the Internet, but causes some problems such as suboptimal routing and multiple encapsulations. The proposed scheme, combining Prefix Delegation protocol with HMIPv6 concept can provide more effective route optimization and reduce the amount of packet losses and the burden of location registration for handoff. It also uses hierarchical mobile network prefix (HMNP) assignment and provides tree-based routing mechanism to allocate the location address of mobile network nodes (MNNs) and support micro-mobility. In this scheme, Mobility Management Router (MMR) not only maintains the binding informations for all MNNs in nested mobile networks, but also supports binding procedures to reduce the volume of handoff signals over the mobile network. The performance is evaluated using NS-2.

▶ Keyword : 미시적이동성 (micro-mobility), 중첩된 이동 망 (nested mobile network), 계층적 (Hierarchical), 경로최적화(route optimization)

• 제1저자 : 노경택
• 접수일 : 2006.09.28, 심사일 : 2006.10.16, 심사완료일 : 2006.11.05
* 서울보건대학 인터넷정보과 교수

1. 서론

A mobile network is the network that dynamically changes its attachment point to the Internet as a single unit and it is composed of one or more MRs and MNNs connected to the Mobile Router (MR). The aggregated hierarchy of mobile networks is called a nested mobile network, where a mobile network may attach inside another mobile network. Network Mobility Basic Support Protocol [1] (hereafter referred to as NEMO Basic) which is an extension of Mobile IPv6 (MIPv6) [2], sets up a bidirectional tunnel between MR and MR's Home Agent (MR-HA). A major drawback of NEMO is that all communications to and from the mobile network must go through the MR-HA tunnel. This results in extra overhead and high delays. Moreover, with nested mobile networks, the problem increases with each nested level. Outbound packets must go through the HAs of all MRs of higher levels before reaching their destination. This is known as the "triangle routing problem" and causes high delay. Another problem of NEMO Basic is related to communications between MNNs within the same nested mobile network. When a CN sends packets to a MNN in the same nested mobile network, These packets are forwarded through different HAs. The reason is due to the encapsulation introduced by NEMO Basic that makes MRs unable to read the destination address of the original packet.

Multiple solutions presented provides the route optimization support for NEMO Basic. In [3], a new routing header called the Reverse Routing Header (RRH) is proposed. This RRH is used to record the route out of the nested mobile networks. Each MR on the egress path places its Care-of Address (CoA) in the RRH. Receiving this header, the HA can construct the chain of Mobile Routers the first MR is attached to. The major inconvenient of this solution is the additional

overhead, introduced by RRH on each packet, which increases with the number of levels of the nested mobile network.

A Hierarchical Prefix Delegation protocol (HPD) [4] is an extended prefix delegation protocol based on Automatic Prefix Delegation Protocol (APD) [5]. How to extend APD for hierarchical IPv6 network is outside the scope of this paper. HPD is not limited to a leaf router and provides efficient network mobility in a nested mobile network. HPD allows routers to request any prefix from upper routers. Once a Requesting Router receives a prefix from its upper router, it can play the role of the Delegating Router. It provides its lower routers with parts of its address space by delegating longer level prefixes, enabling multiple-level hierarchical prefix delegation. Routing tables of routers are updated so MN behind the MR can use its CoA as source address of outgoing packets. It enables the packets to pass the ingress filtering. Thus, the HPD protocol provides optimal routing between correspondent nodes. However, significant signaling load is caused in case that MNNs moves frequently within AR domain.

Improved Hierarchical prefix Delegation Protocol (IHPD) [6] introduces the scheme which combines HMIPv6 [7] concepts with HPD protocol to solve the problems inherent in NEMO Basic such as non-optimal routing, multiple IPv6 encapsulation and micro-mobility. A AR (hereafter referred to as AR(MAP)) acts for mobility administration (i.e., Mobility Anchor Point (MAP) function in HMIPv6) for MNNs within AR domain. The scheme allows the MNN in mobile network to create its Regional CoA (MNN-RCoA) based on MAP prefix sent from AR(MAP) and its Local CoA (MNN-LCoA) based on the delegated MNP advertised from MR in its mobile network. Therefore, LCoA for each MNN obtains a hierarchical address which is topologically consistent with the hierarchical structure of the nested mobile network. Thus, the scheme solves micro-mobility problems and provides optimal

routing paths between the MNNs inside the nested mobile network and the CNs outside the nested mobile network. However, whenever a mobile network moves within the nested mobile network, each MNN in the mobile network has the problem to send a binding update message (BU) to AR(MAP).

Our proposal, HPR reduces the number of control messages required in the IHPD as it enables MMR to update the binding information for MNNs behind a MR, using a BU from the MR instead of MNNs when the MR moves locally within the nested mobile network. HPR also enables packets to be optimally routed to MNNs in the mobile network via MMR. The scheme aims at localizing handoff signals and optimizing the routing.

The remainder of this paper is organized as follows. Section II describes our proposed architecture and provides the detailed routing and handoff procedures. A performance evaluation of the proposed architecture and mechanisms is described in section III. We present some conclusions and future works in section IV.

II. Proposed Routing Scheme

2.1 Hierarchical Address Allocation for MNNs

In order to reduce the packet header size, our proposal makes the HMNP hierarchical to AR, resulting in CoAs which are hierarchical within the nested mobile network. MR acquires a delegated MNP (hereafter referred to as HMNP) from its access router by running HPD protocol when the MR changes its point of attachment. The HMNP is topologically consistent with the hierarchical structure of the mobile network. Suppose that the net mask of the access router (AR), which is an edge router of the nested mobile network, is 29 bits long [8]. The mobile network is allocated a HMNP with a $29 + 7 * (n + 1)$ bits mask as the

nesting level n increases where $n = 0 .. 4$ to form a hierarchical structure with the AR. In this way, CoAs hierarchical to the mobile network are achieved. The MR then advertises a router advertisement message (RA) to its subnet, containing the HMNP and the MMR address as its RCoA. MNNs behind the MR in mobile network make their LCoAs (MNN-LCoA) using the HMNP and sets the MMR address as their RCoA (MNN-RCoA). Then, each MNN in the MR's mobile network send BUs to their CNs, containing MNN-RCoA and MNN-HoA. Packets from CNs are optimally routed to the MNN via MMR, using routing header option (RHO) including the MNN-RCoA. MMR encapsulates the packets with MNN-LCoA after searching for it in its binding cache and sends the packets to the MNN. To provide a hierarchical address based on HMNP for MNNs in a mobile network, let us consider the nested mobile network of Fig. 1. When the MR has multiple links, the MR requests multiple HMNPs of its access router, gets HMNPs from the access router and advertises each HMNP on a separate subnet. After performing HPD procedure, the routing tables of each MR are updated by routing protocol. Therefore, nested MRs maintain routing information about the HMNP. Thus, the hierarchical address allocation method makes it possible to meet the route optimization and packet header size minimization at the same time because a CN can send packets directly to an MNN in a mobile network, using the MNN-LCoA via MMR [6, 8, 9]. On the other hand, when packets contain the LCoA of MNN as its source address, the CN address as its destination address and a HoA of MNN in home address option field, the packets have no problem in ingress filtering, and directly reach CN with route optimization.



그림 1. HMNP 할당
Fig 1. HMNP assignment

its nested mobile network as follows. Table 1 shows MMR’s binding cache that is composed of HoA, CoA, upper-MR, and HMNP fields based on Fig. 1. CoA field contains LCoAs of MNNs which are divided into a node locator and an individual node identifier. The upper-MR field contains the home address of a MR. HMNP field contains a HMNP which represents the location of the subnets of a MR. Additionally, when MMR receives a BU from a nested MR, the proposed solution supports that MMR updates the binding informations for the MR and also MNNs behind the MR, where MNNs in MR’s mobile network can be found using the HoA of the MR in upper MR field.

2.2 Stateless Address Autoconfiguration using HMNP

We choose IPv6 stateless address auto-configuration for MNNs instead of stateful address allocation like DHCP, because stateless address auto-configuration is much more flexible than stateful address allocation. The IPv6 address generated by stateless auto-configuration contains the same interface identifier regardless of the location the MNN is attached to the Internet. The proposed scheme conceptually divides the network address into the node locator indicating the location of the mobile network and the node identifier indicating the location of each MNN within the mobile network. The HMNP assigned to the mobile network to which the MNN currently connect is used as the node locator, and the node identifier is assigned as a globally unique 64-bit identifier [10].

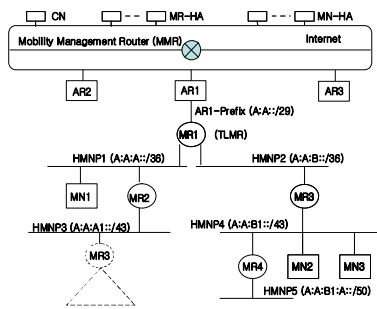
2.3 MMR functionality

To support route optimization, MMR supports the hierarchical rerouting as it maintains all MNN-LCoAs in hierarchical manner [6]. In addition, to provide micro-mobility management when MNN moves locally within the nested mobile network, MMR is allowed to have the MAP function where it keeps the binding information of all MNNs belonging to

표 1. MMR 바인딩 캐시
Table 1. MMR’s Binding Cache

HoA	CoA (locator + identifier)	upper-MR	HMNP
MR1-HoA	MR1-CoA (AR-prefix + mr1)	AR1	HMNP1, HMNP2
MN1-HoA	MN1-LCoA (HMNP1 + mn1)	MR1-HoA1	-
MR2-HoA	MR2-LCoA (HMNP1 + mr2)	MR1-HoA1	HMNP3
MR3-HoA	MR3-LCoA (HMNP2 + mr3)	MR1-HoA2	HMNP4
MR4-HoA	MR4-LCoA (HMNP4 + mr4)	MR3-HoA	HMNP5
MN2-HoA	MN2-LCoA (HMNP4 + mn2)	MR3-HoA	-
MN3-HoA	MN3-LCoA (HMNP4 + mn3)	MR3-HoA	-

2.4 Protocol Operation

This section will show that the proposed solution describes the detailed operations to solve the limitations of other routing scheme as well as the NEMO Basic solution. When MNN changes the point of attachment, the MNN should perform the appropriate location registration to MMR and/or its HA according to whether it connects inside the mobile network or not. An inter-domain handoff of a MN occurs when the MN moves to foreign

network and is directly attached to AR. In Fig. 2, MMR periodically sends its address to AR1 and AR2, which are connected as subordinates of MMR. In Fig. 2-(a), the MN gets AR1-prefix (B::) and MMR address from the AR. The MN creates its RCoA (MMR address) and its LCoA (B::mn) by combining the AR1-prefix (B::) with 64-bits interface identifier (mn). MN sends a BU with the LCoA to MMR and a BU containing the RCoA to MN-HA.



그림 2 핸드오프시 등록절차
Fig 2. Registration Processes in Handoff

On the other hand, in the case that a MR directly accesses to AR2, as Fig. 2-(b) describes, MR1 sends a Router Solicitation message (RS) containing a request for a HMNP to AR2. Then, AR2 sends a RA to MR1, containing delegated MNP (ex, HMNP1) and MMR address. Then, MR1 stores HMNP1, sets MMR address as its RCoA, and creates its LCoA using AR2-prefix (A::). MR1 then sends a BU to its MMR, containing MR1-LCoA and HMNP1 to MMR. MMR registers the binding information, containing the MR1-LCoA, MR1-HoA and HMNP1. After this, MR1 sends a BU to MR1-HA, containing MMR address as its RCoA. MR1 then sends a RA to its mobile network, containing MMR address, HMNP1, and MR1-HoA.

An intra-domain handoff occurs when a mobile network moves within MMR domain. Fig. 3 shows

the occurrence of an intra-domain handoff when MR2 connects to a new point of attachment. MR2 sends a RS to get a MNP. MR2 updates its LCoA and sets MMR address as its RCoA and MRb as its upper MR and stores HMNP2 after receiving a RA from upper MR (MRb) containing MMR address, HMNP2, and MRb-HoA. MR2 then sends a BU to MMR, containing MR2-HoA, MR2-LCoA, MRb-HoA and HMNP2. Then, MMR registers the information to bind the MR2-HoA and MR2-LCoA and MRb-HoA, and HMNP2.

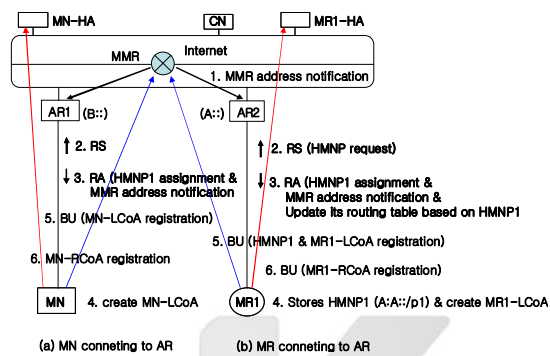

그림 3 도메인 내 이동 망 핸드오프
Fig 3. Mobile Network's Handoff in Intra-domain

MMR then searches the binding entries for MNNs behind the MR2 using the home address of MR2 (MR2-HoA) in upper-MR field of its binding cache. Next, MMR updates LCoAs for all MNNs within MR2's mobile network by changing node locator of LCoA to HMNP2. MR2 sends a RA to MNNs within its mobile network, containing MR2-HoA, HMNP2, and MMR address. Each MNN creates its new MNN-LCoA using HMNP2 in the RA, and also sets its RCoA as MMR address and MR2-HoA as its upper MR. In this way, all MNNs behind the MR also do not need to send BU to the MMR. On the other hand, in the case of the handoff of a mobile network due to the movement of the parent mobile network within a MMR domain, the MR (e.x., MR4 in Fig. 1) repeats

above-mentioned handoff procedure for MNNs within its mobile network, which is performed by upper MR (MR3) for MNNs within MR3's mobile network. Thus, in case that a mobile network moves locally within MMR domain, MR in the mobile network and all nested MRs on lower levels connected to the MR sends a BU on behalf of MNNs within their mobile network.

An intra-domain handoff happens when a MN (MN3) moves locally between mobile networks within MMR domain (Fig. 4). MN3 sends a RS. MN3 receives a RA containing the HMNP2, MMR address, and MR2-HoA from MR2 where MR2 is already connected to AR2 through IMRs.

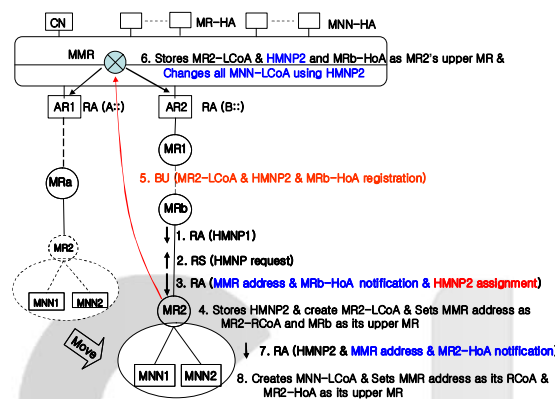

그림 4. 도메인 내 이동 노드 핸드오프
Fig 4. MN's Handoff in Intra-domain

The MN3 detects its movement within the same MMR domain since the HoA of the MR2, which is currently connected to it, differs from the HoA of the old MR (MRa-HoA) and its RCoA (MMR address) is not changed. Then, MN3 creates its LCoA (MN3-LCoA) based on the HMNP2, sets the MMR address as its RCoA and stores MR2-HoA as its new upper MR's address. MN3 sends a BU to MMR, containing MN3-HoA, MN3-LCoA and MR2-HoA. MMR registers the binding information in the BU from the MN3.

III. Performance Analysis

In this section, results of performance analysis are presented where the proposed solution is compared to the NEMO basic, RRH and HPD, using network simulator NS-2. Fig. 5 shows network models for simulation where there may be at least one MR per level below root-MR in nested mobile network. In order to simulate the real traffic, we set up the CN as a traffic source of a constant bit rate (CBR) over a user datagram protocol (UDP), producing fixed length packets of 1500 bytes each every 10 ms. Then the MNN acts as a sink node receiving packets from CN. The wired link bandwidth is set to 100 Mbps with the wired link latency set to 1 ms. The wireless link bandwidth is set to 11 Mbps with the wireless link latency set to 2 ms. The packet service rate was 100 packets/second corresponding to data rates of 1.2 Mbps. We evaluated each scheme assuming 5, 10, 100 MNNs in the mobile network.

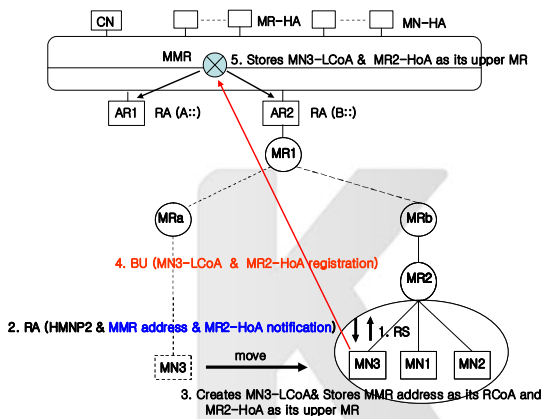
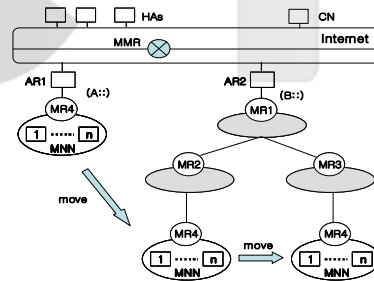

- Distance between HA and HA: 50 hops
- Distance between CN and HA: 25 hops
- Distance between HA and MMR: 20 hops
- Distance between CN and MMR: 20 hops
- Distance between MMR and AR: 5 hops
- Packet header size: 40 bytes
- BU size: 112 bytes
- BACK size: 96 bytes

- Processing time in the MMR: 0.003 ms
- Processing time in HA: 0.005 ms
- Processing time in Router: 0.001 ms

그림 5. 시뮬레이션 네트워크 모델
Fig 5. Network Model for Simulation

3.1 End-to-End Packet Delay

Packet transmission delay measurements from a CN to a MN in the mobile network are depicted in Fig. 6. This is related to the reduction of the number of nested tunnels. Indeed, the proposed solution requires only a unique tunnel from MMR to MN regardless of the number of nested levels in the mobile network.



그림 6. 중점간 패킷지연
Fig 6. End-to-End Packet Delay

3.2 Location Update costs

Fig. 7 shows the location update costs for each scheme as the nested-level increases. Handoff management in HPR is separated into macro mobility and micro mobility. In case inter-domain handoff happens, HPR has the same location costs as HPD. However, When MNN moves within MMR domain, our scheme requires that it only sends a BU message to MMR, compared to CNs/HA in other schemes. The difference of the location update cost between NEMO Basic and HPR is 40.82 ms at level 0 and 457.57 ms at level 4. The difference between RRH and HPR is 40.94 ms at level 0 and 50.64 ms at level 4. The difference between HPD and HPR is 40.61 ms at level 0 and 59.22 ms at level 4. So, our scheme is superior to

NEMO Basic, RRH and HPD. Because 69 % of user mobility is contained within a local domain, an attribute of micro-mobility [10], the proposed scheme has more efficient location update costs than other schemes.

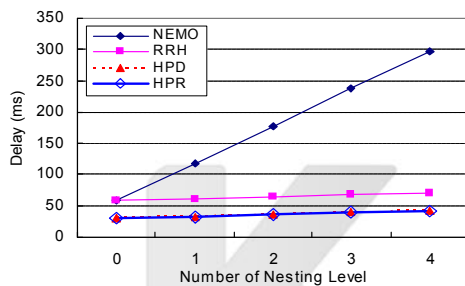

그림 7. 위치갱신비용
Fig 7. Location Update Cost

3.3 Handoff Latency

Handoff latency is the mean time from handoff initiation to completion. Fig. 8 shows the handoff latency for each scheme when a mobile network is assumed to move locally at nesting level 3 within a nested mobile network. NEMO Basic requires that MR only performs a registration operation to its HA and/or CNs instead of MNNs connected to the MR. However, HPR requires that MR also performs a registration operation to MMR instead of MNNs behind the MR. The performance ratio of HPR to NEMO Basic is 0.06 regardless of the number of MNNs in the mobile network because this difference depends on the BU destination. The performance ratio of HPR to RRH method depends on the number of MNNs, i.e., 0.86 with 5 MNNs, and 0.004 with 100 MNNs. HPD has slightly longer handoff latency than RRH because HPD requires ICMP prefix request and delegation operations to get a HMNP due to the handoff of a MR. HPD and RRH also require all MNNs in the mobile network to send BU messages to their CNs and HAs when handoff occurs. As the number of MNNs in the mobile network is increased, the handoff latency of RRH and HPD increases

enormously. Therefore, HPR is the most efficient when compared to other schemes.

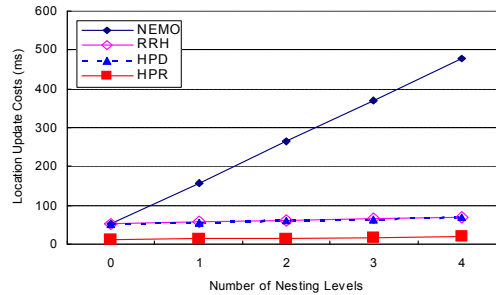

그림 8. 핸드오프 지연
Fig 8. Handoff Latency

3.4 Amount of Packet Losses

Fig. 9 shows the comparison of total packet losses occurring in each scheme when a mobile network with ten MNs moves locally within a nested mobile network from nested level 0 to 3. The number of packet losses increases as the nesting level or handoff latency increases.

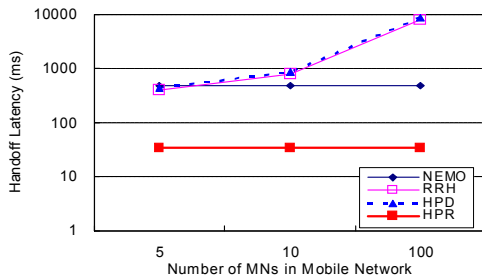

그림 9. 패킷손실수
Fig 9. Amount of packet loss

All MNs as well as MR in a mobile network should send BUs to their HAs and/or CNs in HPD and RRH, which result in longer handoff latency than HPR and NEMO Basic because the MR only sends a BU to MMR in HPR or MR-HA in NEMO Basic instead of MNs when the MR moves locally within the nested mobile network. However, although packet overhead in RRH increases compared to HPD when nesting level increases, HPD results in similar but slightly longer handoff

latency than RRH because each MR, to get a HMNP to be used its subnet, performs prefix delegation operations with its upper MR. The difference of packet losses between the RRH and HPD is about 7 packets regardless of the nesting levels. On the other hand, the difference of packet losses in HPR and NEMO Basic is due to the BU destination. Thus, the discarded packets in AHS are the fewest of the four methods.

IV. Conclusion

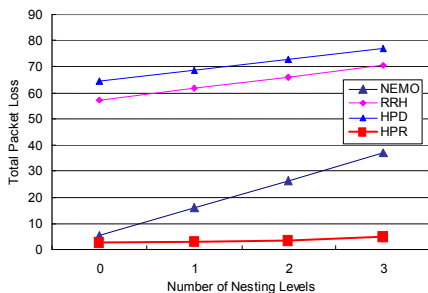
The proposed scheme which combines HMIPv6 concept and HPD solution provides hierarchical re-routing and localizes the management of intra-domain mobility as MMR is provided with the MAP function. Every MR in nested mobile network acquires a HMNP from its access router by running HPD protocol. Each MNN behind the MR creates LCoA and sets MMR address as its RCoA using a HMNP with MMR address from RA, which provides route optimization and minimal packet overhead. Moreover, the proposed scheme added functionality to the MMR so that MMR updates the binding information for all MNNs behind a MR when the MR moves locally in its domain and sends a BU to MMR. Thus, the proposed scheme meaningfully reduces packet transmission delay, handoff latency and packet losses.

참고문헌

- [1] V. Devarapalli, R. Wakikawa, A. Petrescu, and P. Thubert, "NEMO basic support protocol," internetDraft: draft-ietf-nemo basicsupport-03.txt, June 2004.
- [2] D. Johnson, C. Perkins and J. Arkko, "Mobility Support in Pv6", draft-ietf-mobileip-ipv6-22.txt, May 2003.
- [3] P. Thubert and M. Molteni, "IPv6 reverse

routing header and its application to mobile networks, "Internet Draft : draft-thubert-nemoreverse-routing-header-05.txt", June 2004.

- [4] Byung-Yeob Kim, Kyeong-Jin Lee, Jung-Soo Park, Hyoung-Jun Kim, "Hierarchical Prefix Delegation Protocol for Internet Protocol Version (IPv6)", internet draft, October 2003, draft-bykim-ipv6-hpd-00.txt
- [5] B. Haberman and J. Martin, "Automatic Prefix Delegation Protocol for Internet Protocol Version 6 (IPv6)", draft-haberman-ipv6gw-auto-prefix-02.txt, Feb 2002.
- [6] K.T. Rho, "Improved Hierarchical prefix Delegation Protocol for route optimization in nested NEMO", KSCI, Vol. 10, NO. 5, pp227-235, November. 2005.
- [7] H. Soliman, C. Castelluccia et al, "Hierarchical Mobile IPv6 management (HMIPv6)", IETF draft, draft-ietf-mobileip-hmipv6-07.txt
- [8] T.Suzuki, K.Igarashi, A.Miura, M.Yabusaki, "Care-of Prefix Routing for Moving Networks", IEICE TRANS. COMMUN., VOL. E88-B, NO.7 JULY 2005
- [9] K.-J. Lee, J.-H. Jeong, J.-S. Park, and H.-J. Kim, "Route optimization for mobile nodes in mobile network based on prefix delegation", Internet draft draft-leekj-nemo-ro-pd-02.txt, Feb. 2004.
- [10] T. Oiwa, M. Kunishi, M.Ishiyama, M. Kohno, and F. Teraoka, "A network Mobility protocol based on LIN6", IEEE, 2003
- [11] G. Kirby, "Location the User", Communication International, 1995

저자 소개



노경택

중앙대학교 전자계산학과 졸업

(이학사)

뉴저지공대 컴퓨터정보학과 졸업

(이학석사)

고려대학교 컴퓨터학과 박사수료

서울보건대학 인터넷정보과 교수

<관심분야> wireless sensor

networks, mobile

communications, video

communication