

The Impact of the Competitiveness of Intermediate Software on Enterprise Results : a Case Study of Chinese Intermediate Software

Zi-Yang Liu*

Abstract

The purpose of this paper is to draw a conclusion on the impact of intermediate software on enterprise results. In this paper, product innovation and product reliability are especially used as analytical factors. An exploratory analytical study is conducted on the competitiveness of intermediate software, in the hope of gaining a new understanding of the competitiveness of intermediate software. Data are analyzed using such quantitative analytical tools as SPSS and AMOS. Using reliability analysis, validity analysis and structural equation model analysis, the final results are achieved. According to the analysis results, we can draw the following conclusions: the competitiveness of intermediate software has a positive impact on the innovation of software products. The competitiveness of intermediate software doesn't have a positive impact on the reliability of software products. Product innovation has a positive impact on enterprise results. Product reliability also has a positive impact on enterprise results. By analyzing the conclusions, we can make certain suggestions and draw implications on the competitiveness of China's software industry.

▶ Keyword: competitiveness of intermediate product, corporate performance, product innovation, product reliability

I. Research Background and Theoretical Basis

1.1 Research Background

As a strategic leading industry that determines the national competitiveness in the 21st century, the software industry has become the core and soul of the information industry among every nation.

In developed countries, in order to optimize the allocation of resources, control personnel costs and maximize profits in the global market, companies have outsourced some of their non-core software projects to other countries, of which the labour costs are relatively lower. In a way, this behavior has promoted the rapid development of the global software outsourcing industry.

Currently, 1/3 of global software output needs to be outsourced and this data is increasing at an annual rate of 29%. In this case, outsourcing is more and more popular among software enterprises. Meanwhile software outsourcing has become a trend of the development of software industry all over the world. For multinational companies in developed countries, it is also plays an important role in strengthening their market competitiveness.

India, known as the "Office of the World", has become the winner in the software outsourcing market with its advanced software development system management, by

• First Author: Zi-Yang Liu, Corresponding Author: Zi-Yang Liu

*Zi-Yang Liu (morninglzy@hotmail.com), Department of Global Business Graduate School, Kyonggi University, Korea

• Received: 2018. 09. 06, Revised: 2018. 12. 10, Accepted: 2018. 12. 14.

means of which it has also become the world's largest software exporter. Its annual profit from exporting is up to tens of billions of dollars in.

In India, software industry doesn't have a long history, but it has made remarkable achievements. As is known, India's software is a typical export-oriented industry.

They tend to vigorously develop software outsourcing services and expand offshore business. Under this circumstances, Large software companies contract high-end products and services for multinational companies and small and medium-sized software enterprises supply low-end services such as programming and testing. In the end, they have outsourced 303 of the global 500 companies.

Nowadays, software products and services in India have been widely recognized in the world and they are exported to countries all over the world, which make India become the world software supply and development center, and the largest software outsourcing country in the world.

As the largest software outsourcing country in the world, India's main service areas are North America, the European Union and Japan, and the main service targets are the United States, the United Kingdom, Germany, Japan and other countries. Besides, India has been recognized as the most reliable supplier of software by the United States, 60 percent of whose software products purchased by American customers are made in India.

The government and the software industry predict that India's software outsourcing industry will continue to flourish in the near future. According to the World Bank's survey on the national capacity of software exports, India ranks first in the world in terms of scale, quality and cost of software exports, and is the second largest software exporter after the United States in the world.

As a developing country, China shouldn't have been left behind India in software. This is worth pondering why China and India have formed such a huge contrast in the field of software outsourcing.

1.2 Theoretical Basis

There are many papers on the impact of competitiveness on enterprise results. However, there are very few exploring from the perspective of the competitiveness of intermediate products. Studies related to intermediate software, in particular, are even rarer. Papers taking software industry as the object of study

mostly consider from the perspective of business transaction. For this reason, the present study attempts to carry out an exploratory study from the impact of the competitiveness of intermediate software on enterprise results.

The theoretical basis for the competitiveness of intermediate software appearing in this study is integral and modular in Nobeoka Kentaro's MOT Technology Management Getting Started [1], "the force and influence of components, materials and equipment made in China" (2012) by Samsung Economic Research Institute in CEO Information and the product structure theory based on Solutions to Improve the Competitiveness of South Korean Electronics and Automobile Industry from the Perspective of Product Structure by Noh Hyung Jin (2012). On such a theoretical basis, an exploratory study was carried out.

To achieve the expected research goal, we set up a research model from the perspective of the competitiveness of intermediate software. The research model was composed of competitiveness of intermediate product, product innovation, product reliability and enterprise results.

In the selection of industry of interest, we chose China's software enterprises. As China's software industry has developed rapidly since reform and opening up, it produces a profound influence in East Asia and even the whole world. The share of China's software industry in the global market keeps increasing. But it is a pity that profits of China's software industry are on the wane. The biggest reason is that while our exports of finished goods are increasing, our imports of intermediate goods in the high-end market are also increasing. For this reason, we particularly selected software industry to conduct an empirical analysis.

The strategy Noh Hyung Jin (2010) adopted to improve product competitiveness was achieved by integrating the "design and manufacturing strategy" of product architecture and the "customer value strategy" of customer value[2]. The study of Porter, M.E. showed that the lack of competitive advantage would lead to the lack of corporate competitiveness, as well as the benefits brought about by asset creation. Among them, the most important benefit was improved performance. Once a competitive advantage was achieved, it was necessary to maintain and update market conditions. The method to create sustainable competitive advantage represents an answer given by many companies to strive for survival in

a fiercely competitive environment. To realize the method to achieve competitive advantage, there are also many dangers. Every company should be aware of them when it comes to the development of strategies to gain competitive advantages[3]. Rui Zhang suggested that an appropriate thinking mode should be adopted for corresponding design and enhance the effectiveness of innovative product design as a whole[4]. Jadesadalug, Viroj, Ussahawanitchakit, Phapruek believed that a strong tie had a positive impact on the performance of new products, but when we used technological turbulence and intensity of competition as regulators, the interaction would be less significant[5]. Li Xiaozhong and Wang Qianqian argued that as the use of foreign investment in the software industry continued to expand, not only the introduction of a package of elements (e.g. technology and capital) directly promoted capacity expansion and technical progress in the software industry, but also the technical spillovers of foreign investment elevated the technical level of domestic enterprises[6]. Hao Chenjian Dong Guangmao research shows that the basic ability factor is the premise of the existence of enterprise competitive advantage. The cultural integration ability, core talents and corporate financing factors are strongly related to the level of enterprise competitiveness; the external marketing channel and service delivery speed are the specific factors that restrict the business operation ability[7]. Xiaming Liu, David Parker, Kirit Vaidya, and Yingqi Wei show that foreign direct investment may have a positive impact on labor productivity in aided industries through direct introduction of capital, technical and managerial skills, and indirectly through spillover effects on domestic firms[8]. The N Dayasindhu study shows the relationship between the components of a trust-based industrial cluster. Flexible specialization helps to produce a variety of products for specific markets using common resources. Achieve global competitiveness by increasing productivity, centralizing guidance and accelerating innovation and growth[9].

II.Hypotheses and Research Model

The issue of corporate competitiveness has become a common concern in the current society. The survival and competitive environment of enterprises are facing severe

tests. In such an increasingly fiercely competitive market, the competitiveness of enterprises directly or indirectly determines the survival and development of enterprises.[10] Product innovation has always been regarded as an engine of social and economic growth. It is often referred to as a driving force of corporate competitive advantage, because it can distinguish an enterprise from its competitors, promote the ability of existing products to meet customer needs and reduce costs [11]. Fierce global market competitions make more and more enterprises pay increasing attention to the shaping and spreading of brand connotation and brand personality. The rapid growth of brand connotation and brand personality has become an important marketing measure for enterprises to achieve differentiation in market competition [12].

2.1 A research model was built as follows:

Using theoretical research as the basis and integrating findings in other studies, we built the following model shown in Figure1, with the competitiveness of intermediate product, product innovation, product reliability and enterprise results as the factors. (mobile payment).

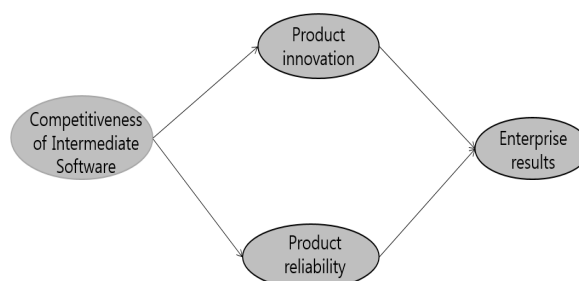

Fig. 1. Model

2.2 Hypotheses

After summarizing the results of previous studies and actual situation, we made the following hypotheses:

H1: The competitiveness of intermediate software has a “+” impact on product innovation;

H2: The competitiveness of intermediate software has a “+” impact on product reliability;

H3: Product innovation has a “+” impact on enterprise results;

H4: Product reliability has a “+” impact on enterprise results.

2.3 operability definition

2.3.1 competitiveness of intermediate software

According to the release of "China's spare parts,

materials, equipment and impacts" issued by the Samsung Economic Research Institute in 2012, in addition, according to Hyung-Jin Rho (2014) "An Empirical Study on the Effects of the Competitiveness of Intermediate Products and Enterprise's Core Competency on Customer Value and Enterprise Performance in Korean and Chinese Enterprises", the intermediate products can be obtained from the beginning of the initial stage to the final stage, the whole chain is different from the raw materials and finished products. In addition, in the research of verifying the competitiveness of intermediate products in the study of Zi-yang Liu & Hyung-Jin Rho (2013), the competitiveness of intermediate products is divided into six items: the independence of the parts, the connection of the two parts, the assembly of the three parts, and the dependence of the four parts.

2.3.2 Product innovation

According to Andrews & Smith (1996), Sheth et al. (2001) and other researchers, product innovation refers to the concept of a new sense of skills and technology that can be felt when the product is used. They divided the product innovation into two items: specificity and characteristics.

2.3.3 Product reliability

Hosmer (1995) explains this for trustworthiness, which is the ability of a system to perform certain functions within a certain time interval under certain conditions, avoiding unacceptable ability to frequently fail. Cummings & Bromiley (1996) considers the system's ability to continuously provide services and restore all services within a specified timeframe when subjected to external attacks or due to human error, environmental influences, and hardware failures and software bugs that cause the system to fail. It is called a comprehensive ability because the standard for measuring this ability is not uniform, nor can it be single, but an evaluation system determined by a combination of factors. Based on the research literature, this paper uses three factors: reliability, usability and operability.

2.3.4 Enterprise results

This paper uses the method of subjective judgment to determine the enterprise results through the form of questionnaires. The questionnaire was based on the competitive advantage theory used by Gupta et al. and the

results of Govindarajan & Fisher (1990). The following four factor indicators were used: 1 market share 2 product sales price 3 product quality and skill 4 development research costs and sales ratio.

III. Research Methods and Results

3.1. Research methods

The present study adopted a common method in social scientific research, questionnaire survey, and used employees in a Chinese software enterprise as the object of study. The duration of survey was from March 10, 2018 to May 4, 2018. After a preliminary survey, the errors in the preliminary survey were corrected and a formal survey was carried out. A total of 300 questionnaires were issued and 253 were recovered. After excluding false questionnaire and other defective questionnaires, a total of 250 valid questionnaires were obtained. Finally, the 250 valid questionnaires were used for analysis, and reliability analysis, factor analysis and structural equation model analysis were conducted using SPSS 22.0.

3.3 Reliability test and appropriateness test

To test the consistency between each variable in the group, reliability analysis was used. Generally speaking, people adopted Nunall (1978)'s Cronbach's α criterion. The benchmark was set to 0.65, above which the value was considered a valid value for reliability. According to the criteria for reliability analysis, the Cronbach's α value is lower than 0.6, and we have removed the operability of the non-compliant product reliability factor level in the analysis (hereinafter referred to as C3). Through the results of reliability test, we can judge that there existed internal consistency between each item measured. According to the measured results (see Table 1), all of the measured reliability structure was above 0.65 and completely fell within our measurement range of reliability.

In the specific statistical analysis, this study simplified the factor levels of each variable and each variable. Simplify the software semi-finished product competitiveness into CIS, simplify the independence of parts in semi-finished products competitiveness to A1, simplify the connection of parts in semi-finished products

competitiveness to A2, and simplify the assembly of finished products in semi-finished products into A3. Simplify the dependence of components in semi-finished products competitiveness to A4. Simplify product innovation into PI, simplify the specificity of product innovation factor level to B1, and simplify the characteristic of product innovation factor level to B2. Simplify product reliability to PC, simplify the reliability of product reliability factor level to C1, simplify the availability of product reliability factor level to C2, and simplify the operability of product reliability factor level to C3. Simplify the company's results into BR, simplify the enterprise's achievement factor level market share to D1, simplify the enterprise result factor level product sales price to D2, and simplify the enterprise result factor level product quality and skills to D3, and develop the enterprise results factor level. The research cost to sales ratio is simplified to D4. The following representations are represented in a simplified manner.

Table 1. Reliability analysis results for each variable

	Cronbach' α	Normalized Cronbach' α	Number of Items
CIS	0.778	0.778	4
PI	0.783	0.786	2
PR	0.824	0.824	2
ER	0.809	0.812	4

Table 2. Validity analysis results for each variable

Item	Component			
	1	2	3	4
D2	0.847	-0.044	0.073	0.066
D1	0.821	-0.004	-0.049	-0.053
D3	0.791	0.071	0.075	0.123
D4	0.715	0.104	0.145	0.07
A2	0.053	0.859	0.047	-0.007
A3	0.041	0.825	0.114	-0.099
A1	-0.044	0.765	-0.05	0.235
A4	0.085	0.599	0.217	0.213
B1	0.114	0.093	0.891	0.101
B2	0.07	0.124	0.886	0.006
C1	0.206	0.053	0.002	0.834
C2	-0.038	0.143	0.102	0.824

Table 2 shows the analysis results of model appropriateness. Through a factor analysis, we can see that all the weights of the concept and attribute of each variable exceeded 0.6. According to the general experience on appropriateness judgment, as long as the weight exceeded 0.4, the model can be usable. The appropriateness of the

model completely fell within the range of appropriateness.

3.4. Research results

When testing the goodness of fit of the overall model, scholars Hair et al. (1998) suggested that first of all, it was necessary to test whether the model parameters had illegal estimates. We can proceed from three aspects: first of all, whether there was a negative error variance. Secondly, whether the coefficient of normalized parameter was greater than or equal to 1. Thirdly, whether there was too big normalized error. If there was no violation in model test results, it was possible to test the fit of the overall model. Generally speaking, the fit of the overall model can be determined by several indicators, such as chi-square degrees of freedom, RMSEA, GFI and AGFI. Through our test, we can calculate that the chi-square value=87.319, the chi-square degree of freedom= 50, RMSEA=0.055, GFI=0.943 and AGFI=0.912. According to the indicator criteria, it was safe to say that this result can pass the criterion of model fit.

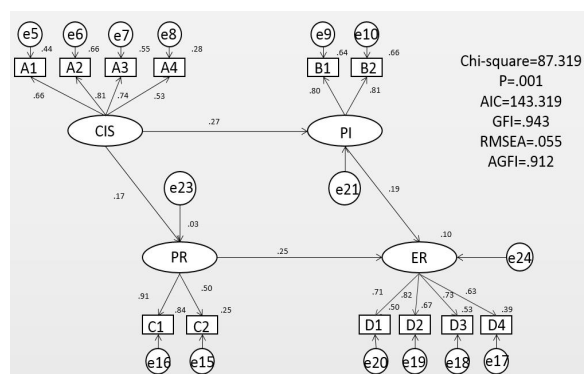

Fig. 2. Structural Equation Model Analysis

Table 3. About the results of each hypothesis test

Hypothesis	Estimate	S.E.	C.R.	P	Conclusion
H1 (CIS→PI)	0.308	0.099	3.115	0.002	Supported
H2 (CIS→PR)	0.134	0.081	1.661	0.097	Not supported
H3 (PI→ER)	0.183	0.078	2.351	0.019	Supported
H4 (PR→ER)	0.341	0.113	3.026	0.002	Supported

According to the test results of hypotheses based on structural equation, we can obtain the following results:

The hypothesis that the competitiveness of intermediate products has a “+” impact on product innovation is a meaningful hypothesis;

The hypothesis that the competitiveness of intermediate products has a “+” impact on product reliability is a meaningless hypothesis;

The hypothesis that product innovation has a “+” impact on enterprise results is a meaningful hypothesis;

The hypothesis that product reliability has a “+” impact on enterprise results is a meaningful hypothesis;

IV. Discussion and Conclusions

4.1 A research model was built as follows:

In the current age of Industry 4.0, most countries and governments advocate the industry of artificial intelligence. As the main core of artificial intelligence, software industry should be brought to the attention of every country. Through the present study, we find that apart from several software countries in the world, most countries' software industry is not at a high level. Especially the intermediate software industry should improve its competitiveness, enhance software innovation and software reliability and contribute to the development of software enterprises. Through hypotheses and model building, after investigation and analysis, we can draw the following conclusions:

First, When intermediate software has certain competitiveness, it is of significant help and have certain influence on product innovation. But if intermediate software has certain competitiveness, it doesn't have a positive impact on product reliability. This suggests that when Chinese intermediate software has certain competitiveness, it is of certain help to product innovation, but still we have a long way to go in terms of the reliability of software enterprises and credibility of products. This also gives some warnings and prompts to Chinese software enterprises, especially software OEMs. Intermediate software processing enterprises also need to set up a new direction, find a new path, try to please customers on software brand and software credibility and win praise from industrial customers and general customers.

Second, Product innovation has a significant impact on enterprise results. Product reliability has a significant impact on enterprise results. That is to say, if products make some achievements in innovation, they will have a great influence and be of great help to enterprise results. This suggests that today when the Chinese society

develops rapidly and seeks transition, the consumers' pursuit for new things and corporate development attach greater importance to product innovation and reliability.

The above are conclusions drawn from data analysis and have great reference significance for research on other fields of enterprises. However, the present study is confined to China's intermediate software industry. In future studies, we will add other industries and regions and carry out an in-depth study.

4.2 Limitations and future research directions

This research is a research result of Chinese software enterprises for research objects. It has certain limitations in geography and industry, and should be extended to various countries and regions to be more meaningful and fruitful.

In addition, there are certain limitations for the research objects in this study. More uniform distribution research should be done. This research mainly focuses on the research conducted by large software companies, which has certain limitations.

In view of this, for the future research direction, it is necessary to expand from geographical differences and globalization to do some follow-up research, and to conduct more comprehensive research on the research, it is best to use a combination of big data to conduct a comprehensive study.

REFERENCES

- [1] Nobeoka Kentaro (2006), MOT Technology Management Getting Started, Nikkei Asian Review, pp.73-86, pp.268-284.
- [2] Noh HyungJin (2010), "A Study on the Advancement of the Competitive Power of Korean Electronics and Automobile Industries from a Product-Architectural Point", 「The Korea Society of Computer and Information」, pp.78-88
- [3] Porter, M.E. , Competitive Advantage: Creating and Sustaining Superior Performance, The Free Press, New York.
- [4] Rui Zhang, Reliability Method on Product Innovation Design, p341-345,2014.
- [5] Jadesadalug, Viroj, Ussahawanitchakit, Phapruek, The Impacts of organizational synergy and autonomy on new product performance: moderating effects of corporate

- mindset and innovation, vol.3No.3,p118-128,2018.
- [6] Li Xiaozhong and Wang Qianqian, Comparative Study of Impact R&D Input and FDI on China's Electronic and High-tech Industries: Estimation and Analysis Based on Total Factor Productivity, Journal of International Trade, No.01, 2014.
- [7] Chenjian Hao, Guangmao Dong, Influential factors of International competitive advantage of Software Outsourcing Enterprises and its empirical Analysis, Enterprise Economy. 20No. 10, 2011.
- [8] Xiaming Liu, David Parker, Kirit Vaidya, Yingqi Wei, The impact of foreign direct investment on labour productivity in the Chinese electronics industry. International Business Review, No, 4, 2011.
- [9] N Dayasindhu, Embeddedness, knowledge transfer, industry clusters and global competitiveness: a case study of the Indian software industry, Vol.22, No.9, pp.551-560, 2002.
- [10] Wang Jian and Zhang Xiaoyuan, Study on Corporate Competitiveness Indicator System, Shandong Social Sciences, No. 11. 2014.
- [11] Han-Mo Oh .Product Innovation through International Joint Venture in Emerging Markets: A Focus on the Role of Joint Market Orientation..Korea Trade Research Institute. 2014.
- [12] The Influence of Brand Spokesmen Credibility on the Perceived Quality of Consumers: The Regulatory Effect of Product Involvement and Product Knowledge, Chongqing Technology and Business University, 2014.

Authors



Zi-yang Liu. Received the B.A. degree in Management from Army superintend institute of shijiazhuang China PLA ,China, in 2006, M.A. degree and Ph.D. degree in Management from Kyonggi University, Korea, in 2010 and 2013,

respectively. Dr. Liu joined the faculty of the Global Business Kyongggi University, Korea in 2015. He is currently an Assistant Professor in the Global Business Kgonggi University. He is intrested in Quality Management. Management Information Systems, International economics, E-business etc.