

A Study of Consumers' Purchasing Intention for National Brands in the Context of Sino-US Trade War – Take China Huawei Company as an exle

HanWen Guo*, Zi-Yang Liu*

Abstract

The purpose of this study is to understand the purchasing intentions of Chinese consumers to Huawei and other domestic brands in the context of the current Sino-US trade war. Taking the mass consumers as the research object, this paper designs Likert five-level scale to investigate consumers' purchase intention of domestic products in the future, and uses SPSS 23.0 and AMOS 23.0 statistical software to analyze and process statistical data. Using questionnaire survey and exploratory factor analysis, this paper constructs a model to analyze the impact of consumer ethnocentrism on consumers' purchase intention. By summarizing the overall purchasing intention of consumers, it is concluded that the development of domestic brands in the context of trade war is facing difficulties and challenges in the future, but at the same time, we must seize the opportunity of consumers' ethnocentrism under this background to positively influence their purchasing intention, make up for shortcomings, eliminate overcapacity, and seek greater development through technological innovation.

▶ Keyword: Trade war, Consumer ethnocentrism, Domestic product awareness, Product Evaluation, Purchasing Intention

I. Introduction

Since March 2018, the United States has imposed large-scale tariffs on imported goods worth 60 billion US dollars, and restricted the investment, financing and merger and acquisition business of some Chinese enterprises to the United States, thus opening the chapter of the trade war. As of early May 2019, under the background of continuing negotiations between China and the United States, the United States Government unilaterally announced that it would impose 25% tariffs on Chinese imported goods worth 200 billion US dollars. In mid-month, the U.S. Department of Commerce officially announced that Huawei and dozens of its supply chain

affiliates would be included in the list of export control entities. This means that Huawei will no longer be provided with technology and product materials from American companies. Since then, the United States has proposed a "hypothetical threat" to impose a long-term commercial and technological blockade on Huawei and other companies. As the United States mainly levies taxes on high-performance medical devices, new materials, industrial robots, new generation of information technology and so on, the Sino-US trade war is both a crisis and an opportunity for Chinese enterprises. Huawei responded on the 20th that it has the ability to continue

• First Author: HanWen Guo, Corresponding Author: Zi-Yang Liu

*HanWen Guo (921106ghw@gmail.com), Department of Global Business Graduate School, Kyonggi University, Korea

*Zi-Yang Liu (morninglzy@hotmail.com), Department of Global Business Graduate School, Kyonggi University, Korea

• Received: 2019. 06. 17, Revised: 2019. 07. 08, Accepted: 2019. 07. 08.

to develop and use the Android ecosystem. The services provided by its smartphones and tablets are in China. The market is not affected. Wang Zhijun, Vice Minister of Industry and Information Technology of China, responded in an interview that China should solve the problem of core technology shortcomings, guide, encourage and give full play to the innovative ability of enterprises. At the same time, the central government should increase its support for the stability of basic research of enterprises, improve the operation mechanism of innovation, and guide local enterprises and social forces to increase investment in basic fields [1].

Huawei has maintained a super-fast growth in recent years, and in 2018, its business income exceeded \$100 billion, becoming the first technology company in China with business income exceeding \$100 billion. In mobile communication technology, Motorola was born in 1G era, Ericsson and Nokia were born in 2G era, Qualcomm and Apple were born in 3G era, while Qualcomm was still in the position of giant in 4G era, but Huawei company of our country has stepped into the center of the battlefield of giant competition. Every innovation of communication technology will bring new giants, not only for technology companies. In itself, for the country, this is a very critical thing, and after the current 5G era of hegemony will lead the development of Internet of Things, artificial intelligence and other technologies, and has been given the expectation of unveiling the next industrial revolution. The Sino-US trade war has had a great impact on the technological development and trade environment of the two countries and even the world. Ren Zhengfei, president of Huawei, once said that "Huawei is a commercial company. For Huawei's products, consumers like to use them, they don't need to use them if they don't like them. Huawei's products should not be linked to politics." However, under the technological blockade of the United States, Huawei's main mobile phone and PC market will be greatly affected. As Intel has to stop its business contacts with Huawei due to the restrictions of the U.S. trade war policy, it is difficult for domestic chips to enter the mainstream position in a short time. According to the author's conjecture, Huawei's PC business may progress slowly in the future. On the other hand, Huawei has obtained the permanent authorization of ARMv8 level in the mobile phone market, so Huawei will continue to hold a strong competitiveness in the mobile phone market, but the market has many competitors, fierce competition, and

the threat of potential entrants in succession, and the duration and scope of the trade war will have a significant impact on Huawei's main business market.

Although the external environment is not good, Huawei is also constantly improving its various aspects to meet market demand. Chinese consumers' attitudes and perceptions towards domestic platforms and their resistance to the past are constantly transforming into acceptance. Under the special background of trade war, whether consumers will be more willing to buy their own products under the influence of national pride and collective national self-esteem will be introduced in this paper. These concepts and their exploration, and finally come to the conclusion that Huawei Company as an exile for the development of other domestic brand companies to provide strategic recommendations in the context of the trade war.

II. Research theory and research background

2.1 Consumer ethnocentrism

Consumer ethnocentrism was first put forward by Shimp (1984) in the field of marketing. This concept is mainly used to reflect a consumer's consumption habits. It trusts and buys domestic products, but it is equal to unpatriotic performance for purchasing foreign products[2]. Subsequently, Shimp and Sharma (1987) proposed that consumers with high ethnocentrism would consciously resist foreign products, while consumers with low ethnocentrism would pay more attention to the cost-performance ratio of goods [3]. Baker (1995) found in the survey that the national image of the manufacturing country has a more significant impact on consumers' purchase intention. He believed that the excellent national influence would make the high-fame-centric consumers more inclined to buy their own products in their consumption choices[4]. Becic M (2016) found in the survey of Turkish and Bosnian college students that the level of education affects the level of ethnocentrism, and they are positively related[5].

2.2 Domestic Product Awareness (DPA)

National product awareness is a concept put forward by Chinese scholars on the basis of China's national conditions. The background of the term is that a large

number of foreign capital stationed in the mainland domestic market in the early years, which led to difficulties in the development of Chinese national capital. The state studies and puts forward to revitalize national capital. Zhou Ming (1990) first put forward the concept of "national product awareness" in his article "A Brief Comment on the Consciousness of National Goods"[6]. Wang Haizhong (2002) tested Shimp and Sharma's Consumer Ethnocentrism by empirical research, which proved that the experiment was equally effective under China's national conditions [7]. Wang Peng (2010) divided the sense of national goods into two dimensions: pride and crisis after studying the operation results of the Beijing Olympic Games[8].Ma Xiangyang and other scholars in the study of cultural identity and regional brands show that patriotism includes a sense of mission, responsibility and pride in the country. This is a strong feeling of the nation for the country[9].

2.3 Model establishment

The term intent originated from the field of psychology. Fishbein (1975) defined intent as the subjective probability of a person's specific behavior, and purchase intent is the subjective probability of buying behavior[10]. Dodds (1991) and other scholars defined purchase intention as a possibility based on Fishbein's definition. This possibility is used to measure the probability of consumers buying a product. They believe that consumers' attitudes and external factors constitute consumers' purchase intention [11]. When researching consumers'willingness to buy online channels, Chu Tanming concluded that consumers would measure the quality of service, product appearance, whether there is a brand effect, product value, etc. [12].When Guo Shuai and other two scholars studied consumer psychology, they found that the reputation of consumers can become the driving force of purchase intention[13].

III. Research models and assumptions

3.1 Research Model

This paper uses the above variables to explore the relationship between consumer ethnocentrism and purchasing intention, and takes consumer ethnocentrism as an independent variable influencing factor, and puts

forward a research model. The ethnocentrism in the study is described by two concepts: national pride and national collective self-esteem. National product awareness and product evaluation are both intermediary variables of the model, which ultimately affect consumers' purchase intention. Kelman's theory of social impact is used in the model construction.After the improvement of Kelman's theory by Venkatesh, the author points out that the identification mechanism is an act that an individual objectively considers others' viewpoints to be accurate and effective and then adopts them. The internalization mechanism is that under certain social factors, individuals think that certain behavior is consistent with their own ideas and adopt them [14].The term "product evaluation" refers to the conclusion drawn from the judgment and analysis of products. Because the article studies the buyer's market and purchasing intention of consumers, it intends to introduce this variable, starting from the two aspects of consumers'national pride and national collective self-esteem, and ultimately influencing purchasing intention through national product awareness and product evaluation. The specific relationship between variables is shown in Figure 1.

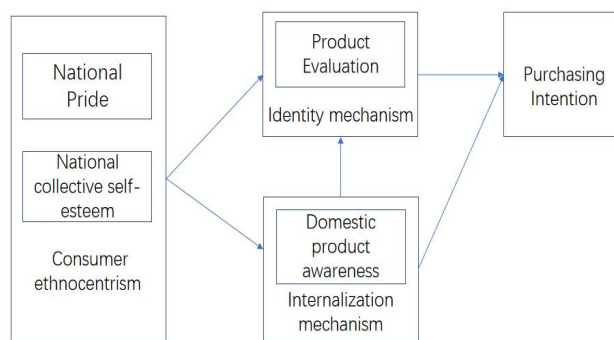

Fig. 1. Purchasing Intention Model

3.2 Consumer Ethnocentrism and Identity Mechanism

Under the background of the US-led trade war, ethnocentrism has cled down on Huawei's market and development. The public opinion of a large number of consumers in the Chinese market will lead to support for Huawei, and regard Huawei as a new hope for domestic technology companies; Huawei itself continues to Enhancing the competitiveness of products also wins the favor of consumers. Combined with the unique business background of the current trade war, subjective and objective product evaluation will have an impact on other

consumers. Wang and Yu believe that people will make inferences about the source of the evaluation information, and the recommendation from friends is more persuasive [15]. Zhang Yi (2018) divides patriotism into several dimensions such as national pride and national collective self-esteem based on the balance of “big self-small-national goods” [16]. Based on the above findings, the following assumptions are made:

H1a: National pride will positively influence product evaluation;

H2a: National collective self-esteem will positively influence product evaluation;

3.3 Consumer Ethnocentrism and Internalization Mechanism

The sense of domestic product of the internalization mechanism is the recognition and respect of domestic products by Chinese consumers for their enthusiasm for the country and their pride in the nation, and it produces a complex that is proud of buying domestic products. Han Xiaolin (1995), a Chinese scholar, found in the early research on the awareness of Chinese goods that foreign domestic products were mostly derived from the sense of superiority to the country, while China's awareness of domestic products originated from concerns about the national economy [17]. Balabanis (2001) found that ethnocentrism began in the process of studying consumers in Turkey and the Czech Republic, beginning with a love and loyalty to the country, which has a strong social influence on the country's feelings. The strength of the country is gradually strong, and the rising ethnocentrism will drive the internalization mechanism of social influence. Therefore, the following assumptions are made:

H1b: National pride has a positive impact on domestic product awareness;

H2b: Collective awareness will have a positive impact on the awareness of domestic products;

3.4 Mediating Role of Identity Mechanism and Internalization Mechanism

Social impact theory holds that the process of identification and internalization will have positive effects on individual behavior and attitude respectively. Specifically applied to the composition of consumer purchasing behavior: on the one hand, under the influence of the internalization mechanism, consumers and groups with national product awareness will use the background

of trade war to put their eyes back on the domestic product market, thus positively affecting consumers' purchasing intention. On the other hand, under the role of identity mechanism, consumers will accept the purchase opinions and information of other consumers in society, and have a positive understanding of the purchase intention. According to Horton and Wohl, if consumers are immersed in the internalization mechanism of social influence, they will be more vulnerable to the influence of their friends [18]. Based on the above cognition, this paper proposes the following hypothesis:

H3: Product evaluation has a positive impact on purchase intention.

H4: The awareness of domestic goods has a positive impact on purchasing intention.

H5: National product awareness has a positive impact on product evaluation.

H6: Product evaluation plays a mediating role in the relationship between ethnocentrism and purchase intention.

H7: The awareness of Chinese goods plays a mediating role in the relationship between ethnocentrism and purchase intention.

IV. Data analysis and hypothesis testing

4.1 Research Scale and Data Collection

This research is based on the background of Sino-US trade war, and the consumers' willingness to buy Huawei products and even domestic brand products, as well as the intermediary role of identity and internalization in the purchase process. The research of this paper collects data in the form of questionnaire survey. The questionnaire is designed with Likert scale 5. The content of the questionnaire is divided into the basic information of the tester and the possibility perception of the product purchase intention of the tester after he understands the impact of Sino-US trade war. The study first conducted a small group questionnaire to test the reliability and validity of the questionnaire. After revision, the questionnaire was conducted for the groups who knew about the trade war to ensure that the questionnaire had high reliability and validity. A total of 480 questionnaires were sent out, and 416 questionnaires were finally recovered and rejected.

4.2 Data analysis methods

This paper uses SPSS 23.0 statistical analysis software to test the reliability and validity of the collected questionnaire data, and uses AMOS 23.0 result equation software to test the hypothesis put forward in the above article. In this paper, exploratory factor analysis is used to test the reliability and validity of the measurement model, as shown in Table 1. Subsequently, correlation analysis is used to analyze the variables proposed in this paper, as shown in Table 2.

Table 1. Reliability and validity analysis of the model

Variable abbreviation	Variable	Cronbach'α	AVE
NP	National Pride	0.943	0.724
NCSE	National collective self-esteem	0.948	0.925
DPA	Domestic product awareness	0.831	0.798
PE	Product evaluation	0.942	0.647
PI	purchase intention	0.873	0.657

Table 2. Exploratory Factor Analysis

NO.	Matrix				
	1	2	3	4	5
1	.739	.289	.237	.287	.140
2	.740	.309	.294	.248	.181
3	.738	.309	.288	.157	.203
4	.761	.320	.291	.119	.140
5	.615	.366	.286	.233	.330
6	.750	.402	.228	.148	
7	.321	.679	.300	.302	.219
8	.350	.808	.234	.150	.124
9	.379	.788	.236	.171	
10	.265	.754	.286	.235	.151
11	.365	.754	.276	.152	.202
12	.321	.679	.300	.302	.219
13	.315	.379	.681	.250	.247
14	.423	.320	.652	.221	.226
15	.407	.374	.646	.233	.212
16	.505	.366	.644	.180	
17	.195	.151	.146	.862	.260
18	.280	.334	.360	.733	
19	.255	.248	.339	.409	.692
20	.255	.282	.154	.568	.622

Table 3. Variable mean & correlation coefficient

Variable	mean	NP	NCSE	DPA	PE	PI
NP	3.26	1				
NCSE	3.32	0.795**	1			
DPA	2.85	0.625**	0.619**	1		
PE	3.20	0.841**	0.804**	0.672**	1	
PI	3.03	0.650**	0.647**	0.793**	0.694**	1

According to Table 1 Table 2 and Table 3 above, the Cronbach'a values of the items are between 0.83 and

0.95, which are all greater than 0.7. The validity test of KOM Bartlett test is 0.971, and the AVE value is between 0.64 and 0.93, which all meet the criteria, indicating that the questionnaire has good reliability and validity. Table 2 shows the results of the exploratory factor analysis after the rotation matrix, We set the screening coefficient value to be greater than 0.6 to get the table. Table 3 shows that there is a good discriminant validity among the variables, indicating that the data can be used to test the equation model.

4.3 Analysis of Structural equation model

According to the hypothesis model and the test results of reliability and validity, we can construct the structural equation model, which is shown in Figure 2.

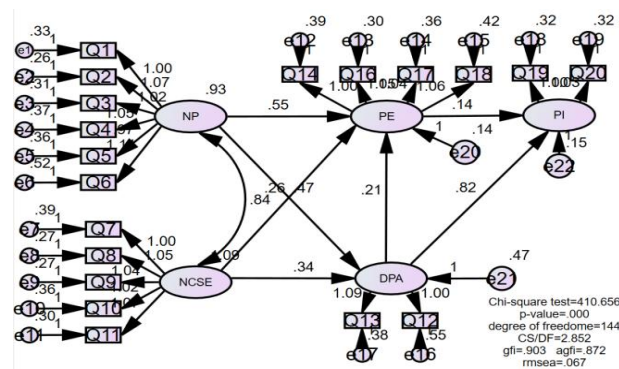

Fig. 2. Purchasing Intention Model and Test Results

Analysis of Figure 2 shows that the chi-square value = 410.656, P value approaching 0, GFI = 0.903, AGFI = 0.872, RMSEA = 0.67 and other results can be obtained. According to the criteria of indicators, we can definitely determine that this result can be determined by the criteria of model fitness.

After determining the composite criteria of the equation model, we can get the conclusion in Table 4 as follows. In the conclusion, the absolute value of the test statistics (critical ratio C.R value) is greater than 1.96, and the P value is less than 0.05. We can judge that all the proposed path assumptions are supported.

Table 4. Hypothesis Test Results

hypothesis	Estimate	S.E	C.R	P	conclusion
NCSE→DPA	0.039	0.078	4.342	***	Support
NP→DPA	0.470	0.086	5.460	***	Support
NP→PE	0.551	0.062	8.941	***	Support
DPA→PE	0.211	0.045	4.728	***	Support
NCSE→PE	0.264	0.052	5.042	***	Support
PE→PI	0.138	0.069	1.996	0.046	Support
DPA→PI	0.818	0.079	10.338	***	Support

4.4 Testing the Mediating Effect of Identity and Internalization

In order to make the verbal conclusion more precise, this paper further studies the mediating role of identity and internalization mechanism between ethnocentrism and purchase intention. According to the test criteria, whether the values of confidence interval LLCI and ULCI contain 0, the lower limit of interval can not pass through 0, and keeping the same number can show that the mediation effect is effective. The positive value of Effect can show that the mediation effect is positive. The specific data as shown in Table 5, all the data in the table meet the above evaluation criteria, and we can fully confirm that the results meet the test criteria.

Table 5. Analysis of Mediating Role of Identity and Internalization

Mediating variable	Effect	Boot S.E.	Boot LLCI	Boot ULCI
NP→PE→PI	0.461	0.062	0.338	0.586
NP→DPA→PI	0.432	0.042	0.349	0.511
NCSE→PE→PI	0.401	0.052	0.294	0.503
NCSE→DPA→PI	0.399	0.040	0.325	0.484

V. Research conclusions and Enlightenment

5.1 Research conclusions

The results of this study show that: national product awareness and product evaluation play a full intermediary role. In the context of the current trade war, patriotism of domestic consumers positively affects their purchasing intention through two mechanisms: internalization mechanism - national product awareness and identification mechanism - product evaluation. In the process of impact, higher awareness of domestic products will also have a positive impact on product evaluation. We can deduce that under the influence of trade war, Chinese consumers show strong patriotism, which has strong appeal. With the growing strength of domestic brands, consumers focus on domestic products again, while some consumers who support domestic brands for a long time are more likely to drive and influence other consumers around them. In the case of national product awareness and continuous improvement of product evaluation support, it will have a more positive impact on consumers' purchasing intentions for domestic brands.

5.2 Countermeasure and Suggestion

Trade balance is a necessary condition for all countries in the world to seek peaceful development. Today, the interests and destinies of all countries are closely linked, deeply integrated, and jointly building a new type of international relations of mutual respect, equality and mutual benefit is the common aspiration of all countries. Throughout history, there has never been a winner in the trade war. Negotiations between China and the United States need to be based on the principles of fairness, justice and cooperation. Only by returning to the negotiating table and seeking common development can they meet the aspirations of the two peoples and the interests of relevant countries. To sum up, during the trade war, enterprises should seize the opportunity and deal with it calmly.

1. Take precautions against danger in safety and do a good job in the medium and long-term strategic layout of enterprises. Huawei, as a Chinese technology company, is facing both crises and challenges in the end of the trade war. As early as decades ago, President Ren Zhengfei mentioned Huawei's situation and crisis in his book "Huawei Winter". Now, when the major international technology companies have broken down Huawei's support because of the "hypothetical threat" policy of the United States, Huawei can rely on its own years of research. The self-made "Hongmeng" system shows the reality to the global consumers, which not only greatly inspires the national self-confidence of Chinese consumers, but also proves their scientific and technological strength to the people of all countries in the world. At present, China and the United States are the only countries in the world with four important factors of technology, talent, market and capital, which means that China has formed a complete set of its own. The capacity of a complete ecosystem. Through this study, Chinese consumers in the context of the trade war, nationalism has a positive impact on the willingness to buy domestic products. Domestic enterprises should learn from Huawei to prepare for the rainy day, to think about the dangers, and to build their own brand while consumers put their eyes back to the domestic market.

2. Take scientific and technological innovation as the guide, make structural adjustment and productivity transformation well. The development and progress of human history lies in the development of productive forces. The crisis brought about by the trade war is also

an opportunity. How to turn the crisis into an opportunity is a topic for entrepreneurs. Nowadays, new technologies, new formats and new industries are emerging in an endless stream in the world. Especially with the advent of the industrial 4.0 era, new and technological enterprises will have great potential. It is incumbent upon entrepreneurs to rely on China's huge talent, capital and market to solve the difficulties faced by enterprises, as well as the problems of worldwide scientific creation and kinetic energy conversion. Secondly, enterprises should start from the application, make use of Kechuang to solve the problem of productivity, make structural adjustment and strategic layout, in order to cope with the changing market.

3. Cultivate innovative teams and build their own brands. Patriotism is the driving force behind the development of national brands, which can stimulate people's desire to purchase and market potential. The nationality is also the world. If a country or a nation wants to develop, it must lead development with technological innovation, master the world's leading technology and independent research and development capabilities, have independent research and development brands, cultivate innovative teams, and increase capital investment for talent training. In the case of scientific research and innovation, it can be invincible in any situation.

REFERENCES

- [1] Liu DeBin Sino-US trade disputes force Chinese enterprises to enhance their innovation capability. Sina's Domestic News. <https://news.sina.com.cn/c/2019-05-24/doc-ihvhiew4247924.shtml>.
- [2] Shimp Terence A. Consumer ethnocentrism: the concept and a preliminary empirical test[J]. *NA-Advances in Consumer Research* Volume, 11(1):285-290, 1984 .
- [3] Shimp T A Sharma S.Consumer ethnocentrism Construction And Validation Of The CETSCALE[J]. *Journal of marketing research*, 28-289, 1987.
- [4] Baker M J,Vallington L. Country of origin as a source of competitive advantage[J]. *Journal of Strategic Marketing*,(10):157-168, 1998.
- [5] Becic Merjema.An Assessment of Consumer Ethnocentrism Tendencies Scale among University Students: The case of Turkish and Bosnian Students[J]. *Inquiry-Sarajevo Journal of Social Science*, 2016, 2(1):119-130.
- [6] Zhou Min,On the Consciousness of Domestic product awareness[J]*Economic work communication*, (19) 28, 1990
- [7] Wang HaiZhong, Consumer Ethnocentrism: China's Empirical and Marketing Interpretation[M], Beijing: Business Management Press, 2002
- [8] Wang Peng, Zhuang GuiJun, The Impact of Beijing Olympic Games on Chinese Consumers' Consciousness of Domestic Goods[J]*soft science*, 24(4):130-134. 140, 2010
- [9] Zhang Jian. Patriotism is not equal to narrow nationalism [J]. *People's Forum*, 2016 (22): 18-19.
- [10] Fishbein M. ,Ajzen I.Belief ,Attitude ,Intention,and behavior:An Introduction to Theory and Research [J].Reading,MA:Addison-Wesley, 16-50,1975.
- [11] Dodds W B.,Grewal D.,Monroe K B.Effects of price, brand and store information on buyers' product evaluation[J].*Journal of Marketing Research*, Vol.28, 1991.
- [12] Chu TangMing, A STUDY SELECTION INTENTION OF CONSUMERS'ONLINE SHOPPING CHANNEL BASED ON SOR THEORY:OFFICIAL WEBSITES AND THIRD PARTY FLAGSHIP STORES AS EXLES [C], 2018. 06
- [13] Guo Shuai, Yin Chengyu. Different Face View of Consumer to the Marketing Information Framework of Reaction:Research Based on Regulatory Focus Theory[J]. *Chinese Journal of Management*. 2015, 12(10):1529-1535, 1522.
- [14] Kelman H.C Compliance. Identification, and Internalization: Three Processes of Attitude Change[J]. *Journal of Conflict Resolution*, 2(1):51-60, 1958.
- [15] Wang Y.C.,Yu C.H.Social Interaction-based Consumer Decision-making Model in Social Commerce:The Role of World of Mouth and Observational Learning[J]. *Interactional Journal of Information Management*, 15(4):2-11, 2015.
- [16] Zhang Yi, Li BinXin, Research on Chinese Consumers' Domestic Goods Consciousness: Retrospect and Prospect[J], *Business economy*, (01) 26-33, 2017.
- [17] Han XiaoLin, Liu XiangMing, Discussion on "One National Goods" in Modern China, *Journal of Jiaying University*, 1995-04
- [18] Horton D., Wohl R.R.Mass Communication and Para-social Interaction:Observations in Intimacy at a Distance[J]. *Psychiatry-Interpersonal and Biological Process*, 19(3) :215-229, 1956.

Authors



Hanwen Guo. Graduated from Guang Xi University. Now studying for a doctor degree at Kyonggi University. HanWen Guo Admitted the Kyongggi University. Korea in 2018. During the school period, the main research interest is Global Business,

E-Business and marketing .



Zi-yang Liu. Received the B.A. degree in Management from Army superintend institute of shijiazhuang China PLA ,China, in 2006, M.A. degree and Ph.D. degree in Management from Kyonggi University, Korea, in 2010 and 2013, reapectively.

Dr. Liu joined the faculty of the Global Business Kyongggi University, Korea in 2015. He is currently an Assistant Professor in the Global Business Kgonggi University. He is intrsted in Quality Management. Management Information Systems, International economics, E-business etc.