

## Using Motivation of Short Video Advertising Marketing in China: An Exploratory Study of Douyin

Nai Zeng\*

\*PhD course, Faculty of Journalism and Communication, Communication University of China, Beijing, China

### [Abstract]

This paper aims to study the using motivation and influencing factors of Chinese users' participation in live stream shopping through theoretical and empirical analysis, so as to evaluate the change in users' needs and improve marketing strategies. In doing so, I conducted a questionnaire survey for Chinese live stream shopping users and collected the required data. For empirical analysis, I used SPSS and AMOS software to carry out descriptive analysis, reliability and validity analysis and structural equation model analysis (SEM) to test the hypothesis. The results of the analysis showed that core competency and brand personality of the short video industry have a significant impact on user and customer perceived value, thus influencing users' using motivation. That is, users do not blindly follow live stream shopping but make their active choice. Therefore, it is suggested that live stream shopping platform should strengthen the e-commerce attributes and eradicate "the sense of false satisfaction", in order to achieve the effective communication of information. On the other hand, to stimulate the purchase motivation of users, the brand should build up its personality, and enhance user and customer perceived value in cyber marketing.

▶ **Key words:** Short Video, Using Motivation, Advertising, Live Stream Shopping, News, Social Media

### [요 약]

본 논문의 연구 목적은 이론과 실증 분석을 통해 중국 사용자의 라이브방송 구매 참여동기와 영향 요소를 연구하고, 사용자의 수요 변화를 파악하여 트렌드에 맞는 마케팅 전략을 수립하는 것이다. 연구목적 달성을 위해 중국 라이브방송 구매자 대상으로 설문조사를 실시해 필요한 데이터를 수집했다. 실증 분석은 SPSS와 AMOS 분석 소프트웨어를 사용해 통계 분석, 신뢰성 및 유효성 분석, 구조 방정식 모델 분석을 수행하여 가설에 대해 검증하였다. 분석 결과를 보면 단편 동영상 업계의 핵심 경쟁력과 브랜드 개성이 사용자의 가치 인식에 반영되어 사용 동기에도 영향을 미치는 것으로 나타났다. 즉, 사용자의 라이브 쇼핑 참여는 맹목적인 순종이 아니며 능동적인 선택권이 있는 전자 상거래 속성을 더욱 강화하고 "허위 만족"을 없애야 정보가 효과적으로 전파될 수 있다. 브랜드측은 사용자의 구매 동기를 부여하기 위해 온라인 마케팅의 개성을 강화하고 사용자의 가치를 존중하는 것이 필요하다.

▶ **주제어:** 단편 영상, 사용 동기, 광고, 실시간 구매, 소셜 미디어

- 
- First Author: Nai Zeng, Corresponding Author: Nai Zeng, Chief Correspondent, China News Service South Korea Bureau
  - \*Nai Zeng (zengnai0717@163.com), Faculty of Journalism and Communication, Communication University of China
  - Received: 2021. 08. 09, Revised: 2021. 08. 27, Accepted: 2021. 08. 27.

## I. Introduction

Ranging from short video to live-streaming-driven sales, Douyin has become a new generation of e-commerce platform for nationwide consumption. According to the 2020 Douyin Data Report, the short-video app has accumulated more than 600 million daily active users. Each user on average spends 98 minutes per day watching short videos and live streaming on Douyin. Due to the change of platform rules and user needs, its trend of live-streaming-driven sales is evolving from video-centeredness to vertical integration in live broadcasting. Since Douyin issued restrictions prohibiting links to third-party platforms in August 2020, Douyin stores have been mushrooming and expanding; Douyin Business accounts and Brand Broadcasting have taken a sharp increase in proportion.

Back to 2013, the rise of social platforms propelled Internet advertising to change the traditional marketing model; and native advertising set off a boom and caused controversy in the academia. Supporters maintain that the hidden advertising model involves both entertainment value and advertising information, appeals to emotional appeal, and triggers the cognition of users' peripheral route; it reduces the noise interference in communication and is conducive to better communication effect. [1]

However, it's also been argued that native advertising is simply another form of the traditional "Content Marketing" or "Branded Content".

In its nascent development stage, building the image of a brand or Vlogger used to be Douyin's mainstream marketing model, which focused on using hidden intention to persuade consumers and was in line to some extent with native advertising. Nevertheless, live stream shopping has become a daily consumption habit on social platforms, turning Douyin users' hidden consumption demand into explicit demand. Live streaming-driven sales and short video content marketing are also growing

distinct from each other. It can be said that in terms of form, the marketing model of Douyin is returning to the traditional path of advertising. And from the perspective of analyzing user needs, the attributes of social media have fundamentally changed users' search habits and consumption psychology.

## II. Literature review

Uses and Gratifications theory (UGT) first surfaced in the 1940s, which is a classic theory of communication study. It seeks to understand the audience's psychological needs and motivations, and explores the influence of media on users. The reason why this theory has been enduring and even become increasingly active in the study of new media communication is that its research focus has shifted from traditional communicator-centered to audience-oriented, correcting Magic Bullet theory or the Hypodermic Needle theory among others. After having been revised for decades by multiple scholars, the theory is shifting from the early analysis of the needs met by specific media content to the study of relevance between audience motivation, audience enthusiasm and communication effect. [2]

UGT with empirical basis has been debated by critical school as to its limitations, which focuses on the premise of UGT, namely UGT as a legitimate vehicle for assessing user activity. Critics argue that the functionalist perspective of UGT ignores the complexity of encoding and decoding as well as the relationship between people and media. Meanwhile, the prevailing theory has been applied rampantly to some extent. British scholars Boyd-Barrett & Newbold have long proposed that the theory of Agenda Setting and UGT should be combined towards a new orientation integrating audience-centered and media-centered approach.[3]

UGT occupies an important position in China's academic research. Publications concerning the

use of UGT found through a CNKI-based search using the keywords “Uses and Gratification Theory”, and a hand search were reviewed. According to CNKI (China National Knowledge Infrastructure), the first paper on “UGT” was published in 2002. Its author Chen Chongshan, one of the earliest scholars in this field in China, was the first to put forward the idea that studying audience can be considered as a research topic; and audience-oriented communication serves as the cornerstone of media.[4]

The decade following her paper has witnessed a dramatically growing number of relevant articles published by Chinese scholars, mainly focusing on: 1. used UGT to analyze a particular social phenomenon; 2. applied UGT to analyzing specific users’ motivations and characteristics, and used the correlations to predict various factors; 3. validated the social and psychological features that affected media use; 4. Held in-depth discussion concerning the theory of UGT.[5]

Among the vast amount of research, the representative studies on theory construction are based on interpreting the changes in the outlook on audience. For example, Chinese scholar Zhao Zhili analyzed the diversified needs of audience and contended that network is not only a way of information communication, but also a manner of life and work, thus constructing a new view of audience.[6] Sui Yan pointed out that at the arrival of the era of mass communication, we should blaze a trail in the middle between the completely passive audience and the hyperactive audience.[7]

Throughout the academic development in China in recent years, UGT has mostly been used for empirical research and quantitative analysis, mainly concentrating in communication effect of different media. Less innovation has been devoted to the level of academic theory.

UGT has been plagued by criticisms in China by the Critical School. Hu Yiqing, one of the representative scholars, proposed three “fatal problems” of the theory. First, the theory rests on

a false assumption that the individual has agency over their media consumption; second, the relationship between man and media is simplified as uses and gratifications, which lingers at the level of phenomenon and functional description, thus affecting the depth of theory; third, the theory transforms communication issues into social psychological ones, which is against the in-depth development of communication studies.

In the current study of UGT, we should first pay attention to the attributes of various platforms. As McQuail noted in the second edition of *Communication Models for the Study of Mass Communication*, when applying UGT to analyzing social media, it is necessary to distinguish between instrumental media use and ritualized media use. The former has the practical purpose of obtaining required information and is applicable to information media; the latter is suitable for entertaining and imaginative use of media, providing audience with cultural experience and helping them to get escapist pleasure. Although social platforms such as Douyin and Kuaishou boast certain information properties, they serve more as “ritual” media.

Second, there remain some limitations in the study of audience based on UGT. For example, empirical research fails to focus on the influence of social factors and culture on media consumption. Therefore, we should comprehensively analyze the media use environment and users’ personalized data, and uphold the interdisciplinary idea combining quantitative and qualitative research.

Third, the application of UGT in China is based on the special characteristics of the times and social background. China’s mass communication is not purely commercial. It has long been dominated by the state media, with mainstream news agencies, television stations and newspapers all taking on a certain national flavor. But the rise of new media constructed on huge commercial capital has prolonged impact on social psychology.

### III. Hypotheses and the Model of Concepts

#### 3.1 model construction

Given the extant research and combining features of advertising and marketing in social media platforms, the model of factors that influence using motivation was established. Based on the logic chain of how the core competency of short-form videos and brand personality of advertisements affect user and customer perceived value, this paper analyzes the influencing factors of users' using motivation, and forms a conceptual model:

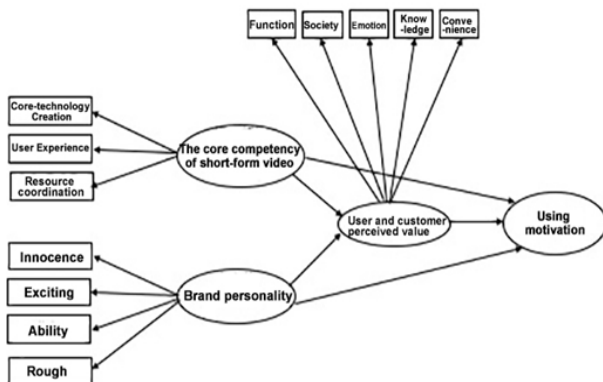

Fig. 1. User motivation model

#### 3.2 research hypothesis

The correlation between the core competency of short-form videos, brand personality and user and customer perceived value.

According to the research on the influencing factors of user and customer perceived value, Dai Debao and Gu Xiaohui (2017) [8] proposed that the function value and sentimental value perceived by users and customers are derived from the experience of using social networks; behavior of interaction and creation have displayed significantly positive effects on perceived value and loyalty. Zheng Jiaoliang and Lu Baozhou (2019) [9] adopted Amos20.0 statistical analysis tool to study the factors influencing user participation in social network platforms and concluded that "the quality of system has a significantly positive impact

on the perceived value of users' participation in mobile social network platforms". Additional research supports the idea that brand experience affects brand loyalty through perceived value [10]; the image of brand product and corporation has a significantly positive correlation with customer perceived value[11].

We therefore hypothesize the following:

H1: The core competency of short-form videos has a significantly positive impact on user and customer perceived value.

H2: Brand personality has a significantly positive impact on user and customer perceived value.

The correlation between the core competency of short-form videos, brand personality, user and customer perceived value as well as using motivation.

Qian Jie and Pan Hongtao noted that [12], in socialized media, when consumers choose audio and video content related to the brand, the characteristics of the content itself directly affect the choice of consumers; consumers' uses and gratifications of brand-related user-generated audio and video content plays an intermediary role in the formation of content characteristics and brand attitude. Scholars Wang Xiwei, Liu Weili, Jia Fengqi and Zhang Chuang (2020)[13] utilized UTAUT model and found that user and customer perceived value positively affected users' usage intention and indirectly affected users' usage behavior. A large body of research shows that the more consumers could feel about brand personality, the better opinion they hold of the brand. [14]

Therefore, based on the research above, I decided to put forward the additional hypotheses:

H3: The core competency of short-form videos has a significantly positive impact on using motivation.

H4: Brand personality has a significantly positive impact on using motivation.

H5: User and customer perceived value has a significantly positive impact on using motivation.

## IV. Data Collection and Research Results

### 4.1 research method

In accordance with the research purpose and the characteristics of the research object, I used a questionnaire survey from April 16, 2021 to April 20, 2021 by targeting short video users in China. This study collected 100 questionnaires, and improved and modified the original questionnaire based on feedback of the 100 customers; then a total of 373 formal questionnaires were issued. After collecting the questionnaires, I used Excel to check the data and found 23 invalid questionnaires. 350 valid questionnaires were actually responded with a response rate of 93.8%. Finally, 350 valid questionnaires were used for analysis, and SPSS 22.0 and AMOS 22.0 software were adopted to test reliability, factor analysis and SEM.

### 4.2 Operational definition of variables

In this study, the operational definition of the core competency of short-form video industry is based on the views of Rod Coombs (1996) and Chinese scholars. The core competency of short-form video industry is divided into three dimensions including innovation of core technology, user experience and resource coordination. Correspondingly, the quantitative measurement is carried out from three aspects, i.e., precise content distribution, competitive PGC (professional generated content) Platform, and viral marketing communication.

As for the operational definition of brand personality, I took for reference the dimensions of brand personality created by Aaker (1999) through empirical research and chose the four dimensions of sincerity, competence, excitement and ruggedness.

The operational definition of user and customer perceived value is identified by reference to the analysis of enterprise competitiveness strategy based on customer value by Liu Jiaojiao (2018),

which classified the customer value of service enterprises into the following five aspects including functional value, social value, sentimental value, value of knowledge, and value of convenience.

The operational definition of using motivation is identified by reference to the literature of Luo (2002), and three indicators are designed to measure using motivation, namely “society, entertainment and information”.

### 4.3 Reliability Test

Reliability analysis mainly measures the stability and reliability of variables by checking internal consistency. There are four methods in common use for conducting the reliability analysis. These are: 1. Test-Retest (Repetition) 2. Alternate or Parallel Forms 3. Split-Half Technique 4. Alpha Coefficient.

The research adopts alpha coefficient. Cronbach's alpha coefficient between 0.80 and 0.9 suggests high reliability, whereas Cronbach's alpha between 0.70 and 0.60, and between 0.61 and 0.65 respectively indicate reliability moderately well and accepted. Cronbach's alpha coefficient is proportional to the reliability of the measured content, that is, the greater the  $\alpha$  coefficient, the greater the reliability of the measured content.

Table 1. Exploratory factor analysis results

Variable types	Variable	number of entries	Cronbach's $\alpha$
The independent variables	CCSV	3	0.800
The independent variables	BP	4	0.913
Lurking variable	UCPV	5	0.923
The dependent variable	UM	3	0.887

Through SPSS statistical analysis, Cronbach's alpha coefficient of each variable are all above 0.6, indicating the internal consistency of each item and sound stability, which conforms to the reliability measurement range in this study.

### 4.4 Validity Test

The scale adopted in this study has been widely used to measure core competency, brand personality and user loyalty. It has endured the empirical test of foreign and Chinese scholars alike and has established a profound theoretical and practical basis for its universal applicability. Therefore, the validity analysis in this study only examined the construct validity of the questionnaire, that is, whether the measurement results could prove the existence of the hypothesis, which also indicated that the expected evaluation might to a great extent be replaced by the final results.

The purpose of adopting factor analysis is to describe the relationship between many questions or variables in the questionnaire with a few factors, and to reflect most information of the questionnaire data with a few factors as well.

Table 2. Test of Hypothesis Results

Project	Composition			
	1	2	3	4
UCPV2	0.860			
UCPV4	0.814			
UCPV3	0.806			
UCPV1	0.791			
UCPV5	0.636			
BP1		0.894		
BP2		0.821		
BP3		0.818		
BP4		0.789		
UM3			0.796	
UM2			0.772	
UM1			0.711	
CCSV3				0.874
CCSV2				0.834
CCSV1				0.722

The validity model results in the above table were obtained through SPSS statistical analysis. Through factor analysis, it showed that all variables displayed a value over 0.6, indicating a good construct validity of the scale.

Bagozzi and Yi (1988) proposed to test the basic fit index of the model from four aspects: 1. There

can be no negative error variances in estimated parameters; 2. All error variance must reach significant level (the value>1.96); 3. The absolute values of estimated parameter and statistics related to each other should not be too close to 1; 4. The factor loading between the potential variable and its measurement index is better larger than 0.6. Therefore, if the basic fit index of the model is valid in the above four aspects, the overall fitness test of the model can be conducted. The test results can be determined by Chi Square statistics, and indicators such as AIC, GFI and AGFI. The following results were obtained through the test: Chi-square value =295.761, AIC=367.761, GFI=0.902, AGFI=0.86. According to the criteria for index determination, the results could pass the criteria for model fitness.

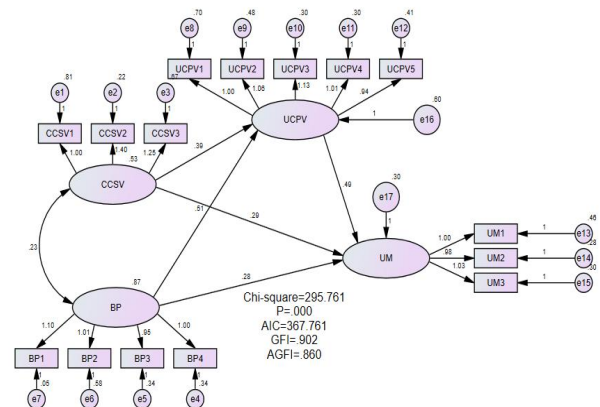

Fig. 2. Structural Equation Model analysis (SEM)

### 4.5 Verification of Hypothesis Results

Table 3 shows the indices for the evaluation of hypothesis testing results.

Table 3. Test of Hypothesis Results

			Estimate	S.E.	C.R.	P
UCPV	<---	CCSV	0.386	0.077	5.029	***
UCPV	<---	BP	0.512	0.059	8.667	***
UM	<---	UCPV	0.485	0.056	8.595	***
UM	<---	CCSV	0.287	0.063	4.519	***
UM	<---	BP	0.281	0.05	5.585	***

Based on the hypothesis test results of SEM, there was enough evidence to accept hypotheses

H1, H2, H3, H4, and H5.

H1: The core competency of short-form video industry has a significantly positive impact on user and customer perceived value.

H2: Brand personality has a significantly positive impact on user and customer perceived value.

H3: The core competency of short-form video industry has a significantly positive impact on using motivation.

H4: Brand personality has a significantly positive impact on using motivation.

H5: User and customer perceived value has a significantly positive impact on using motivation.

## V. Conclusion

### 5.1 Significant changes have taken place in the emotional appeal of Chinese users

The results of the survey are important in many ways. First, it has been found that the appeal to sentimental value accounts for a high proportion of user and customer perceived value, and affects the using motivation to some extent. That is, social media advertising is no longer simply doing the work of information communication or persuasive communication, but also playing the noteworthy role of emotional communication. Maslow's hierarchy of needs classifies human needs into five categories which are physiological needs, safety needs, love and belonging needs, esteem needs, and self-actualization needs. When video communication evolves from the traditional one-way communication in the field of radio and television into the two-way communication mode where users can enjoy real-time Messaging (RTM) while watching videos, advertisements are endowed with new emotional connotations which includes three higher levels of needs: love and belonging, esteem, and self-actualization. How to meet the newborn needs of audience is becoming one of the important factors for advertisements to achieve the

expected communication effect, and also the key to promoting secondary consumption of users.

### 5.2 The attributes of platform have increasing influence on using motivation

The results showed that the using motivation of users is affected by the content distribution pattern of platforms, which means that the attribute of platforms will affect the users' using behavior. Unlike in the past, social media now entered into the field of commercial capital which spurred its vigorous development. And the "gateman" guarding information communication was no longer the official media, but commercial capital, which promoted the quantitative change of China's social culture, user psychology and business structure. This result provides an indication that the advertising communication of social platforms has both the nature of marketability and publicness. Any intention of challenging the bottom line of the advertising marketing model will damage the overall image of the platform and alter the choice of users.

Therefore, platform operators and advertisers should re-understand how communication and technology have changed social life. ByteDance, the company that owns Toutiao and Douyin, has not for five years hired its own team of editing content since its establishment in 2012. Not until in 2018 that it began to recruit on a large scale a team of content approval editors[15]. The primary attributes of the "ritualized" medium have largely influenced psychological expectations and behavior choices of audience. Take Douyin for instance. It should determine its identification, that is, whether it is a platform for e-commerce or information communication. These two identities should be distinguished with clear boundaries.

### 5.3 Brand personality as the "king"

The results have shown that despite the bidirectional and interactive communication model created by social media, the interaction cannot be

guaranteed to be benign or meet the expectation of communicators. Given the significantly positive impact of brand personality on using motivation, audience are found to have the consciousness of active selection, and their usage behavior is not completely influenced by the pattern of information communication. In addition, some studies found that the satisfaction of consumers does not necessarily lead to word-of-mouth communication, and only when the consumer satisfaction reaches a certain high level will they have follow-up behavior.[16] The Internet era is witnessing a large amount of "false satisfaction" which might have contributed to information communication but cannot truly transform into consumption. As a result, I recommend brand owners to make more efforts in shaping their brand personality and improving product quality. The ideal communication effect will not be achieved through network marketing alone. And it is a delusion to reverse the reputation of an inferior brand merely via network marketing.

#### 5.4.Limitations and Future Work

The findings of this research must be viewed in light of the following limitations. One obvious issue is regarding the lack of analysis on the influence of gender and social environment differences upon using motivation. The relationship between man and media is complicated and deeply influenced by the social environment and cultural factors. Though this study reveals the active choice intention of users in this respect, the relationship between the behavior of selection and environmental factors remains to be explored.

Moreover, media and social culture influence each other; the media does not exist solely to meet the needs of audience. Due to the economic miracle sparked by China's Reform and Opening up, the Internet in China has developed with distinct features. Therefore, we cannot apply the western communication theory mechanically to studying the communication in Chinese society. This suggests that

we should combine the study with the characteristics of China's social structure, strengthen the research on the relationship of man and media, and take a closer look at how to release the long pent-up demand of Chinese users in order to better understand the advertising communication effect of social media.

## REFERENCES

- [1] Yu Guoming. "Mosaic, Creativity and Content: Three key words of mobile internet advertising," *Journal of News and Writing*, No.3, March, 2014.
- [2] CaiQi, LiuWeihong."Discussion of the theory of use and gratifications in communication,"*Journal of Hunan Mass Media Vocational Technical College*, Vol. 4, NO. 1, January 2004.
- [3] Oliver Boyd - Barret, Chris Newbold, ed. Wang Kai, Liu Xiaohong, trans "Approaches To Media" BeiJing: Xinhua Publishing House, 2004.
- [4] Chen Chongshan "On Audience-centered Communication" Beijing: Social sciences academic press(CHINA), 2008.
- [5] Cao Qin, Yuan Chenchen "Literature review on the theory of use and satisfaction" *Procedia Journal of Southeast communication*, No. 12, December, 2013.
- [6] Zhao Zhili "a new audience view: use and gratifications under the condition of network communication," *Procedia Journal of Contemporary Communication*, No. 1, 2013.
- [7] Suiyan "The historical evolution and interdisciplinary research of audience view" *Procedia Journal of Journalism & Communication*, No. 8, August, 2015.
- [8] Dai Debao, Gu Xiaohui "User participation behavior, perceived value and loyalty: an analysis based on mobile short video social application," *Procedia Journal of Consumer Economics*, Vol. 33, NO. 2, April, 2017.
- [9] Zheng Jiaoliang, Lu baozhou "User participation behavior, perceived value and loyalty: an analysis based on mobile short video social application," *Procedia Journal of Enterprise Economy*, March, 2019.
- [10] Ou Xia, Lu Dingguang "The impact of brand experience on perceived value and brand loyalty: a case study of Hong Kong cosmetics industry," *Procedia Journal of Journalism Bimonthly*, No.3, March, 2016.
- [11] Wu Jinyue "Research on the influence of notebook brand image on customer perceived value and brand loyalty," *Master thesis: South China University of Technology*, 2016.
- [12] Qian Jie, Pan Hongtao "Research on the impact of user generated



- content use and satisfaction on brand attitude -- Taking audio and video user generated content as an example," *Procedia Journal of Finance and Trade Research*, NO. 3, March , 2012.
- [13] Liu Weili, Jia Peiqi and Zhang Chuang "Model and Empirical Study on Influencing Factors of online live app use behavior" *Procedia Journal of Library And Information Service*, Vol. 64, NO. 5, 2020.
- [14] Yuan Mingshun "Brand personality, consumers' true self and brand attitude" *Procedia Journal of Commercial Research*, No. 3, March , 2013.
- [15] "JinRi, TouTiao will build the largest content editing team in China (cited 2021. 05.)" <http://www.chinanews.com/business/2018/01-03/8415185.shtml>
- [16] Wang CaiYu "The connotation, formation mechanism and influence effect of consumer self brand connection" *Procedia Journal of Advances in Psychological Science*, No. 5. May , 2013.

## Authors



Nai Zeng Received the Bachelor's and Master's Degrees from Communication University of China, Currently Studying for a Doctoral Course in Journalism and communication school from Communication

University of China. Nai Zeng has been working in China News Service (CNS) since 2013 and became chief correspondent in CNS South Korea Bureau in 2018. Nai Zeng's main research area includes media ecology, network communication and media history.