

Publication state: Japan
ISSN: 2435-0702

Publisher: J-INSTITUTE
Website: <http://www.j-institute.jp>

Corresponding author
E-mail: shinhb@kmu.ac.kr

Peer reviewer
E-mail: kinesiology@j-institute.jp

<http://dx.doi.org/10.22471/kinesiology.2020.5.1.65>

© 2020 J-INSTITUTE

The Structural Relationship among Safety Climate, Motive to Participate, and Leisure Satisfaction Level of Marine SPORTS Participants

Kim Sung-hun¹

Yonsei University, Seoul, Republic of Korea

Hong Seong-jin²

Honam University, Kwangju, Republic of Korea

Shin Hong-bum^{3*}

Keimyung University, Daegu, Republic of Korea

Abstract

The purpose of this study is to analyze the actual relationship between the linkage structure and the structural model of participation motive and leisure satisfaction in situations where the safety of marine sports is guaranteed.

The total of 217 subjects was selected by convenience sampling technique among those who enjoy marine sports such as windsurfing, scuba diving, kayak, jet ski, and motor boat with the survey questionnaire developed for this study. The validity and reliability of the measurement tools used in this study were verified by a group of four experts. The validity of the tools was verified by confirmation factor analysis, and the reliability was verified with Cronbach's α coefficient. Analyzable data were processed according to the purpose of the study using SPSS 18.0 and AMOS 18.0. Internal consistency was verified through confirmatory factor analysis and reliability analysis, and structural equation modeling(SEM) was performed for correlation analysis and to examine the causal relations among the variables.

The research model set up in this study was tested to be fit, and the hypotheses according to the research model were verified and the results were obtained as followed. (1)The marine sports safety climate utilized in this study was found to have a positive effect on motives to participate meaning that ensuring safety will further boost participation in marine leisure sports and bring about a lot of development. (2)Safety climate in marine sports has been shown to have a positive effect on leisure satisfaction. Providing a better safety climate for those who enjoy leisure activities is thought to be a natural way to enhance satisfaction. The water leisure facility, where safe climate is set, provides a foundation for participants to enjoy the activities with confidence and further promotes vitality. (3)Motive to participate was found to have a positive effect on leisure satisfaction. Leisure satisfaction has a significant effect depending on the degree of participation in marine sports.

It could be concluded that individuals participating in marine sports programs chosen as a way of leisure gain great satisfaction through marine sports activities. However, facilities, equipment, program operators, leaders, and managers related to high-risk sports should prioritize ensuring safety through system-wide safety and thorough education and must recognize that educational actions that value the importance of safety are paramount. If safe and beneficial programs are continuously provided through this, the participation rate and satisfaction will improve, resulting in quantitative and qualitative development of the marine sports industry.

[Keywords] Safety Climate, Participation Motive, Leisure Satisfaction Level, Structural Relationship, Marine Sports

1. Introduction

Sports activities in everyday life can induce increased leisure time into more constructive and creative activities, and prevent various modern diseases to improve health and physical strength

to adapt to modern society. In addition, it plays a major role in the development of the welfare society by promoting the awareness of the common people through participation in sports activities. Sports as a leisure activity are also an important tool for improving the quality of life by leading a life in society and making people feel happy[1].

Marine sports have continued to develop with the spread of leisure culture due to the recent five-day workweek settlement and economic growth, and the number of opportunities for people to pay attention to and participate directly in marine sports has also increased[2].

Marine sports are thought to be high-risk and therefore have the image of being a sport with a high probability of safety accidents[3] and are also classified as sports with serious risks that could impede safety[4]. The causes of the marine sports accidents are various, but in particular, the lack of safety facilities and education are considered to be the most important factors among the many variables affecting safety behavior since the recent 'Ferry Sewol' incident. This highlights the importance of safety climate in providing marine sports facilities and programs[5].

Safety climate can be defined as individuals' awareness of safety issues felt by members in a system[6], in which accidents decrease as individuals become more aware[7]. The leading factors in system safety can be considered to play an important role in preventing various safety accidents by influencing educators' interest in safety and improving awareness through thorough training of marine sports participants[8]. In other words, educational actions that value the value and importance of safety are the top priority.

It is not easy to grasp the motive of those who participate in high-risk sports. Whatever the motive, it is not easy to decide to participate in such sports. However, if safety is guaranteed, the perceptions of those participating may change[9]. According to humanist psychologist Abraham Maslow, people's actions are motivated in order to achieve certain needs. Motive refers to a trigger that causes something to happen[10], and based on this, it is thought that there is a high relevance between securing safety and participating in high-risk sports. A safe state is a peaceful state from danger or threat and everyone wants to be in a safe state[9][10]. But if there is motive or safety to act at risk, as Maslow claims, people's interest in achieving high-level needs will increase.

The previous studies related to marine sports mainly include one related to safety[11], one related to the revitalization of marine sports[12], and one related to leisure life[13][14]. These studies identify and analyze the behaviors and thoughts of participants in the actual field, but research on the linkage structure and structural model between the factors is insufficient. Therefore, the purpose of this study is to analyze the actual relationship between the linkage structure and the structural model of participation motive and leisure satisfaction in situations where the safety of marine sports is guaranteed. Through this, the researchers hope to help establish a safety culture for marine sports, prevent accidents, increase participation, and revitalize the marine sports industry.

2. Research Methods

2.1. Research subjects

The subjects of this study were 217 samples that were significant in a survey of 250 participants selected by convenience sampling among those who enjoy marine sports such as wind-surfing, scuba diving, kayak, jet ski, and motor boat.

Table 1. Characteristics of the research subjects.

Variables	Description	Frequency(%)	Total(%)
-----------	-------------	--------------	----------

www.kci.go.kr

Gender	Male	118(54.4)	217(100)
	Female	99(45.6)	
Education level	High school	13(6.0)	217(100)
	Junior college	72(33.2)	
	College	105(48.4)	
	Graduate school	27(12.4)	
Sports type	Windsurfing	78(35.9)	217(100)
	Scuba diving	53(24.4)	
	Kayak	38(17.5)	
	Motor boat	48(22.2)	

2.2. Measurement tools, validity & reliability

The validity and reliability of the measurement tools used in this study were verified by a group of four experts (two marine sports experts, one professor of sports psychology, and one doctor of sports psychology). The validity of the tools was verified by confirmation factor analysis, and the reliability was verified with Cronbach's α coefficient.

The criteria for the GFI (goodness-of-fit-index) of the confirmatory factor analysis were set by the study of Bagozzi & Dholakia (2002) and Hong (2000) [15][16], and the criteria for deleting the questions were set by the study of Song (2011) [17]. Song (2011) deleted the questions with low SMC (squared multiple correlations) value based on that the closer to 1 the value, the more explanation power and that the latent variables of 0.4 or below cannot explain the measurement variables [17].

2.2.1. Safety climate for marine sports

To test the safety climate for marine sports, the test questionnaire developed by Kim & Choi (2018) for those participating in marine sports were used [18]. The questionnaire consisted of 16 questions on four factors: communication, practice awareness, safety environment, and safety attitude, with the five-point Likert scale. As a result of the confirmatory factor analysis, two questions with low SMC (squared multiple correlations) were deleted. The GFI for 14 questions was TLI = .909, CFI = .910, and RMSEA = .065, indicating the fitness, and the Cronbach's α coefficient was .821 to .896.

2.2.2. Motives to participate

To test the motive to participate in marine sports, the test questionnaire used in research by Lee, Hyeon & Lee (2015) for those participating in marine sports were modified for this research and used [19]. The questionnaire consisted of 23 questions on five factors: skill, joy, society, fitness, and external display, with the five-point Likert scale. As a result of the confirmatory factor analysis, two questions with low SMC (squared multiple correlations) were deleted. The GFI for 21 questions was TLI = .910, CFI = .914, and RMSEA = .070, indicating the fitness, and the Cronbach's α coefficient was .856 to .897.

2.2.3. Leisure satisfaction level

To test the leisure satisfaction level, the test questionnaire used in research by Im (2010) was modified for this research and used [20]. The questionnaire consisted of 19 questions on five factors: education satisfaction, social satisfaction, psychological satisfaction, physiological satisfaction, and environmental satisfaction, with the five-point Likert scale. As a result of the confirmatory factor analysis,

eight questions with low SMC(Squared Multiple Correlations) were deleted(physiological and environmental satisfaction). The GFI for 11 questions for the remaining three factors was TLI = .922, CFI = .935, and RMSEA = .065, indicating the fitness, and the Cronbach's α coefficient was .901 to .925.

2.3. Data collection and processing

In order to collect data, researchers consulted with and visited windsurfing and marine sports centers to conduct the survey. They explained the contents of the test to the study subjects(n=250), letting them self-administer the survey, and analyzed based on the completed survey(n=217), excluding the insincere responses(n=33) from the analysis. Analyzable data were processed according to the purpose of the study using SPSS 18.0 and AMOS 18.0. Internal consistency was verified through confirmatory factor analysis and reliability analysis, and structural equation modeling(SEM) was performed for correlation analysis and to examine the causal relations among the variables.

3. Results

3.1. Correlation analysis

Pearson's correlation analysis conducted to examine the correlation among each variable showed that there was a statistically significant positive correlation between safety climate sub-variables and participation motive factors. The safety climate and leisure satisfaction were also found to be statistically positively related. There was a positive correlation between motive for participation and leisure satisfaction too. Also, because the value of the correlation coefficient did not exceed .85, discriminant validity was obtained, and there was no problem with multicollinearity as all variables showed less than .80, which is the standard value for multicollinearity.

Table 2. Correlations among variables.

Factors	1	2	3	4	5	6	7	8	9	10	11	12
Communication	1											
Practice consciousness	.550 ***	1										
Safety environment	.399 ***	.352 ***	1									
Safety attitude	.221 ***	.430 ***	.185*	1								
Skill	.433 ***	.409 ***	.605 ***	.173 **	1							
Joy	.411 ***	.342 ***	.344 ***	.201 ***	.580 ***	1						
Society	.390 ***	.314 ***	.599 ***	.233 ***	.637 ***	.573 ***	1					
Fitness	.402 ***	.514 ***	.271 ***	.309 ***	.309 ***	.259 ***	.249 ***	1				
External display	.553 ***	.492 ***	.378 ***	.206 ***	.367 ***	.309 ***	.342 ***	.519 ***	1			
Education satisfaction	.255 ***	.342 ***	.256 ***	.258 ***	.498 ***	.347 ***	.466 ***	.311 ***	.297 ***	1		
Social satisfaction	.455 ***	.418 ***	.287 ***	.392 ***	.432 ***	.348 ***	.415 ***	.334 ***	.502 ***	.600 ***	1	
Psychological satisfaction	.422 ***	.374 ***	.444 ***	.314 ***	.513 ***	.488 ***	.546 ***	.329 ***	.450 ***	.375 ***	.427 ***	1

Note: ***p<.001, **p<.01, *p<.05.

3.2. Goodness-of-fit of model and hypothesis test

3.2.1. Goodness-of-fit of model

To verify the goodness-of-fit of the theoretical model set up in this study and the empirical data collected, a structural equation model analysis was conducted using AMOS 18.0. As shown in the <Table 2>, the theoretical model and empirical data were found to be fit with TLI= .911, CFI= .921, and RMSEA=.070.

Table 3. Goodness-of-fit of the theoretical model.

Q	TLI	CFI	RMSEA
2.260	.937	.952	.076

3.2.2. Hypothesis test

The research model set up in this study was tested to be fit, and the hypotheses according to the research model were verified and the results were obtained as shown in <Table 4> below.

Table 4. Testing of the proposed hypotheses.

Hypotheses	Path	Estimate	SE	CR(t)	Acceptance
H1	Safety Climate → Motive	.716	.074	9.724***	Accepted
H2	Safety Climate → Leisure Satisfaction	.463	.133	3.490***	Accepted
H3	motive → Leisure Satisfaction	.360	.152	2.370*	Accepted

Note: * $p < .05$, *** $p < .001$.

First, as a result of the verification of Hypothesis 1, the hypothesis that "the safety climate in marine sports will have a positive effect on the motive for participation" showed the path coefficient of .716($t=9.724$, $p < .001$), which is a statistically significant difference, indicating that the safety climate in marine sports had a positive causal correlation with the motive for participation.

Second, as a result of the verification of Hypothesis 2, the hypothesis that "the safety climate in marine sports will have a positive effect on leisure satisfaction level" showed the path coefficient of .463($t=3.490$, $p < .001$), which is a statistically significant difference, indicating that the safety climate in marine sports had a positive causal correlation with leisure satisfaction level.

Third, as a result of the verification of Hypothesis 3, the hypothesis that "motive to participate will have a positive effect on leisure satisfaction level" showed the path coefficient of .360($t=2.370$, $p < .05$), indicating that motive to participate in marine sports had a positive causal correlation with leisure satisfaction level.

Figure 1. Path coefficient between variables.

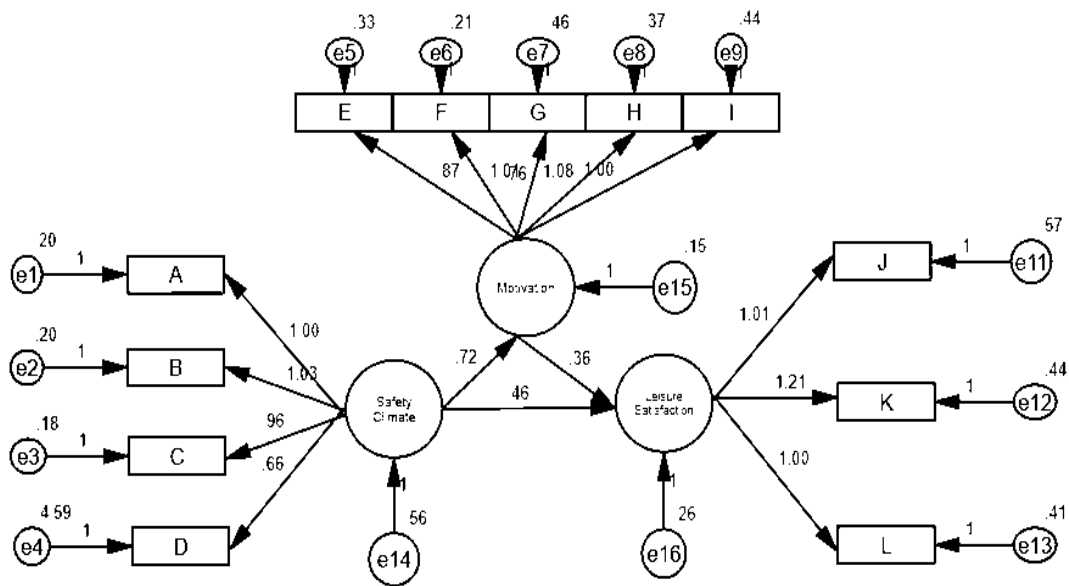

Note: A: Communication, B: Practice consciousness, C: Safety environment, D: Safety attitude, E: Skill, F: Joy, G: Society, H: Fitness, I: External display, J: Education satisfaction, K: Social satisfaction, L: Psychological satisfaction.

4. Discussion

The study was conducted with the aim of analyzing the actual relationship between motive to participate and leisure satisfaction, in the situation where the safety of marine sports is guaranteed. To analyze this, 217 participants in marine sports were surveyed using questionnaire after securing goodness-of-fit and reliability. Based on the results, the discussion and conclusions are as follows.

First, the marine sports safety climate utilized in this study was found to have a positive effect on motives to participate. Kim & Choi(2018) claimed that through the development of a safety climate scale for marine sports, the participants must check their safety attitudes that reflect their commitment to safety before carrying out the exercise[18]. They also said that participants should first inform related parties of their physical and psychological conditions and have an attitude of deciding their participation by recognizing the possibility of safety problems. This could also explore the possibility of how it could affect the promotion of participation if it guarantees the safety of marine sports in the high-risk group. Ahn(2005) stated that safety will, which is the attitude of marine sports participants to their own safety, plays a decisive role in preventing marine sports safety accidents as a keyword for marine sports safety, and supports the results of this study because safety attitude has a strong positive effect on safety participation[21]. It is believed that ensuring safety will further boost participation in marine leisure sports and bring about a lot of development.

Second, safety climate in marine sports has been shown to have a positive effect on leisure satisfaction. Providing a better safety climate for those who enjoy leisure activities is thought to be a natural way to enhance satisfaction. Kim & Yun(2011) analyzed the basic psychological needs of participants in marine and water leisure sports and supported the results of this study by saying that safety issues in leisure sports bring vitality to participation[22]. The water leisure facility, where safe climate is set, provides a foundation for participants to enjoy the activities with confidence and further promotes vitality.

Third, motive to participate was found to have a positive effect on leisure satisfaction. Lee(2009) reported that leisure satisfaction has a significant effect depending on the degree of participation in marine sports, supporting the results of this study[14]. In addition, Lee(2005) reported in his study that although there were differences in variables of motive to participate and leisure satisfaction, they all had significant effects[23][24].

5. Conclusions

Summarizing the results of these various previous studies and this study, one can conclude that individuals participating in marine sports programs chosen as a way of leisure gain great satisfaction through marine sports activities. However, facilities, equipment, program operators, leaders, and managers related to high-risk sports should prioritize ensuring safety through system-wide safety and thorough education and must recognize that educational actions that value the importance of safety are paramount.

Based on the results obtained from this study, future researchers can provide a practical approach to research on specific motives of participants in high-risk sports and type analysis of accident cases and future countermeasures through the results. If safe and beneficial programs are continuously provided through this, the participation rate and satisfaction will improve, resulting in quantitative and qualitative development of the marine sports industry.

6. References

6.1. Journal articles

- [2] Kim JJ & Kim DH. Major Contents and Issues of a Bill: The Act on the Promotion and Safety of Leisure Sports. *The Korean Association of Sports Law*, 51, 71-91 (2017).
- [3] Son SJ. A Study on the Safety Regulation in the Marine Leisure Sports. *The Korean Association of Sports Law*, 10(3), 286-307 (2007).
- [4] Back K & Nam DH. A Study on the Case of Safety Accident in the Marine Sports and its Countermeasures. *The Journal of Korean Society of Safety Education*, 4(2), 5-12 (2001).
- [5] Eid J & Mearns K & Larsson G & Laberg JC & Johansen BH. Leadership, Psychological Capital and Safety Research: Conceptual Issues and Future Research Question. *Safety Science*, 50(1), 55-61 (2012).
- [6] Griffin MA & Neal A. Perceptions of Safety at Work: A Framework for Linking Safety Climate to Safety Performance, Knowledge, and Motivation. *Journal of Occupational Health Psychology*, 5, 347-358 (2000).
- [8] Oh SJ & Lee JH & Lee KH & Mun KS. The Effect of Behavior Based Safety(BBS) Program on Safety Climate and Safety Behaviors: A Field Study. *The Korean Journal of Industrial and Organizational Psychology*, 25(2), 349-372 (2012).
- [9] Slanger E. Motivation and Disinhibition in High Risk Sports: Sensation Seeking and Self-efficacy. *Journal of Research in Personality*, 31, 355-374 (1997).
- [10] Taormina RJ & Gao JH. Maslow and the Motivation Hierarchy: Measuring Satisfaction of the Needs. *The American Journal of Psychology*, 126(2), 155-177 (2013).
- [11] Park GS & Lee YK. The Discourse of Social Mood and Leisure Culture. *The Society of Korean Thought and Culture*, 66, 263-285 (2013).
- [12] Yang MH & Oh YT. A Review on the Research Trends of Marine Sports. *Journal of Marine Sport Studies*, 1(2), 1-20 (2011).
- [15] Bagozzi RB & Dholakia UM. International Social Action in Virtual Communities. *Journal of Interactive Marketing*, 16(2), 2-21 (2002).

- [16] Hong SH. The Criteria for Selecting Appropriate Fit Indices in Structural Equation Modeling and Their Rationales. *Korean Journal of Clinical Psychology*, 19(1), 161-177 (2000).
- [18] Kim SM & Choi MS. The Development of a Safety Climate Scale for Marine Sports. *The Korean Journal of Sport*, 16(3), 253-267 (2018).
- [19] Lee KW & Hyun SJ & Lee HB. Effects of Motivations to Participate in Liberal Dance Classes. *Dance Research Journal of Korea*, 73(5), 94-107 (2015).
- [21] Ahn GY. The Relationship between Safety Climate and Safety Performance, and the Moderating Effect of Age. *Journal of the Korean Society of Safety*, 20(4), 122-129 (2005).
- [22] Kim SM & Youn SM. The Relationship among the Basic Psychological Needs, Exercise Emotion & Vitality for the Participants of Marine/Water Leisure Sports. *Journal of Sport and Leisure Studies*, 43, 67-76 (2011).
- [24] Hofman DA & Stetzer A. A Cross-level Investigation of Factors Influencing Unsafe Behaviors and Accidents. *Personal Psychology*, 49, 307-339 (1996).

6.2. Thesis degree

- [7] Kim JS. The Empirical Analysis on Correlation between Safety Climate and Safety Behavior in the Petrochemical Industry. Korea National University of Transportation, Master's Thesis (2013).
- [13] Lee KB. Participation in Leisure Sports and Life Satisfaction. Korea National University of Education, Master's Thesis (1997).
- [14] Lee JH. Relation between Participation Motive, Sports Immersion and Participation Satisfaction of Marine Sports Participants. Chungang University, Master's Thesis (2009).
- [20] Im TS. The Implications of Skinscuba Participants' Activity on Satisfaction of Leisure. Yongin University, Master's Thesis (2010).
- [23] Lee YM. Relations between Satisfaction in Leisure and in Life by University Students' Motive of Participation Sports Activities. Hannam University, Master's Thesis (2005).

6.3. Books

- [1] Wee SS. Introduction to Social Physical Education. DK Books (1990).
- [17] Song JJ. SPSS/AMOS Statistical Analysis Method. 21C Book (2011).

7. Contribution

7.1. Authors contribution

	Initial name	Contribution
Lead Author	KSH	-Set of concepts <input checked="" type="checkbox"/> -Design <input checked="" type="checkbox"/> -Getting results <input checked="" type="checkbox"/> -Analysis <input checked="" type="checkbox"/> -Make a significant contribution to collection <input checked="" type="checkbox"/> -Final approval of the paper <input checked="" type="checkbox"/>
Corresponding Author*	SHB	-Corresponding <input checked="" type="checkbox"/> -Play a decisive role in modification <input checked="" type="checkbox"/> -Significant contributions to concepts, designs, practices, analysis and interpretation of data <input checked="" type="checkbox"/>
Co-Author	HSJ	-Participants in Drafting and Revising Papers <input checked="" type="checkbox"/> -Someone who can explain all aspects of the paper <input checked="" type="checkbox"/>

7.2. Authors profile

Lead Author

Kim Sung-hun / Yonsei University Researcher

B.A. Myongji University

M.A. Yonsei University

Ph.D. Yonsei University

Research field

- Development of Camp Sport Injury Rehabilitation Outcome Scale for College Soccer Player, *Journal of the World Society of Taekwondo Culture*, 19(3) (2019).
- Development of Camp Training Satisfaction Scale for College Soccer Players, *The Korean Journal of Measurement and Evaluation for Physical Education and Sports Science*, 21(2) (2019).

Major career

- 2015~2019. Honam University, Professor

- 2019~present. Yonsei University, Researcher

Corresponding Author

Shin Hong-bum / Keimyung University Professor

B.A. Myongji University

M.A. Illinois State University

Ph.D. University of New Mexico

Research field

- Examining the Relationship among Acquisition of Sport Rule Knowledge, Enjoyment, and Future Consumption for Preventing Crisis from Challenges in Sport Industry, *International Journal of Crisis & Safety*, 4(2) (2019).
- How Does Sport-related Mobile Apps Usage Motivation Affect Consumer Perceptions of the Sport Organizations?, *Journal of Physical Education and Sport*, 19(4) (2019).

Major career

- 2008~2009. DeSales University, Professor

- 2009~present. Keimyung University, Professor

Co-Author

Hong Seong-jin / Honam University Professor

B.A. Myongji University

M.A. Myongji University

Ph.D. Myongji University

Research field

- Position Difference Analysis and Weighting of Factors of Football Performance, *The Korean Journal of Measurement and Evaluation for Physical Education and Sports Science*, 20(4) (2018).
- Development of Camp Training Satisfaction Scale for College Soccer Players, *The Korean Journal of Measurement and Evaluation for Physical Education and Sports Science*, 21(2) (2019).

Major career

- 2012~2014. Chuncheon National University of Education, Research Professor

- 2014~present. Honam University, Professor